

A110

ALPINE





Welcome aboard your vehicle

This user manual contains the information required:

- for you to familiarise yourself with your vehicle, to use it to its best advantage and to fully benefit from all the functions and the technical developments it incorporates.
- to ensure that it always gives the best performance by following the simple, but comprehensive advice concerning regular maintenance.
- to enable you to deal quickly with minor faults not requiring specialist attention.

It is well worth taking a few minutes to read this manual to familiarise yourself with the information and guidelines it contains about the vehicle and its functions and new features. If certain points are still unclear, our Network technicians will be only too pleased to provide you with any additional information.

For guidance, please see the following symbols:

 and  Visible on the vehicle, they show that you should consult the manual to find detailed information and/or limits on operations in respect of equipment on your vehicle.

→ anywhere in the manual indicates a transfer to a page.



anywhere in the manual indicates a hazard, danger or a safety recommendation.

The description of the models given in this manual is based on the technical specifications at the time of writing. **The manual covers all items of equipment (both standard and optional) available for these models, but whether or not these are fitted to the vehicle depends on the version, the options selected and the country where the vehicle is sold.**

This manual may also contain information about items of equipment to be introduced later in the model year.

The diagrams in the user manual are provided as examples only.

Enjoy driving your new vehicle.

Translated from French. Copying or translation, in part or in full, is forbidden unless prior written permission has been obtained from the car manufacturer.

CONTENTS

Getting to know your vehicle	4	Tyre pressure monitoring system	114
Card	4	Driver correction devices and aids	117
Key, remote control.....	11	Speed limiter.....	121
Doors and opening elements.....	12	Cruise control.....	123
Front seats.....	17	Parking aids	127
Seat belts.....	19	Your comfort	132
Additional safety devices	22	Air vents, heating and air conditioning.....	132
Child safety.....	28	Multimedia equipment	138
Child seats.....	33	Passenger compartment equipment.....	139
Child safety: deactivating, activating the front passenger airbag.....	40	Passenger compartment storage, fittings	142
Driving position	43	Transporting objects	144
Trip computer.....	48	Maintenance	147
Warning lights	68	Accessing the engine, levels	147
Steering	73	Battery	159
Rear view.....	74	Aerodynamic equipment.....	161
Lighting and signals.....	75	Cleaning.....	162
Audible and visual signals	78	Practical advice	165
Wiper	79	Tyres	165
Fuel tank.....	82	Breakdown recovery.....	177
Driving	84	Headlights, lights: replacing bulbs	182
Running in.....	84	Map.....	185
Starting, stopping the engine	85	Wiper blades: replacement.....	187
Choice of driving mode.....	92	Fuses	188
Standing start procedure	94	Fitting a radio.....	193
Gear control.....	96	Installation and use of accessories: important recommendations	194
Special features of petrol versions	103	Operating faults	195
Parking brake.....	105	Technical specifications	200
Environment.....	109	Information about the vehicle	200
Maintenance and antipollution advice	110	Replacement parts and repairs	209
Driving advice, ECO-driving	111		

CONTENTS

Service sheets	210
Anticorrosion check	216

CARD

1

General information



26787

The card is stored in a case.

1. Unlocking the doors and luggage compartment.
2. Locks all the opening elements.
3. Switching on the lighting remotely.
4. Locking/unlocking the rear luggage compartment.
5. Integrated key.

The card is used for:

– locking/unlocking the opening elements (doors and luggage compartment) and the fuel filler flap (refer to the following pages);

- switch on the vehicle lighting remotely (refer to the following pages);
- starting the engine (refer to the information on "Starting the engine" in Section 2).

Range

Make sure that the correct battery type is being used, and that the battery is in good condition and inserted correctly. Its service life is approximately two years: replace it when the "Keycard Battery Low" message appears on the instrument panel (refer to "Card: battery" in Section 5).

i When the battery is flat, you can still lock/unlock and start your vehicle. Refer to the information on "Locking/unlocking the doors" in Section 1 and "Starting the engine" in Section 2.

card operating range

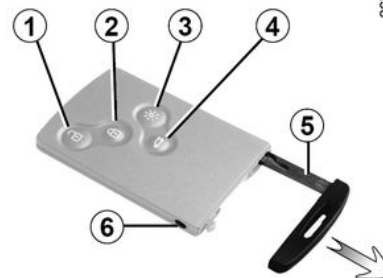

26788

This varies according to the surroundings. It is important to make sure when handling the card that you do not lock or unlock the doors by inadvertently pressing the buttons.

i When storing the card in its case, turn it so that buttons **1, 2, 3** and **4** can be positioned opposite the markings on the case.

CARD

Integrated key 5

The built-in key is used to lock or unlock the front left-hand door if the card is not working:

- when the card battery is drained, flat battery, etc.
- when devices using the same frequency as the card are in use;
- the vehicle is located in a high electromagnetic radiation zone.

Access to key 5

Remove the card from its case. Press button **6** and pull the key **5** then release the button.

Using the key

Please refer to the information on "Locking, unlocking the opening elements".

Once you have entered the vehicle using the integrated key, put it back in its casing in the card.

Store the card in its case.



Driver's responsibility when parking or stopping the vehicle

Never leave an animal,

child or adult who is not self-sufficient alone in your vehicle, even for a short time.

They may pose a risk to themselves or to others by starting the engine, activating equipment such as the electric windows or by locking the doors. Also, in hot and/or sunny weather, please remember that the temperature inside the passenger compartment increases very quickly.

RISK OF DEATH OR SERIOUS INJURY.



Recommendations

Avoid leaving the card in hot, cold or humid areas.

Do not keep the card in a place where it could be bent or damaged accidentally, such as in a back pocket of a garment where it might be sat on.



Replacement: need for an additional card

If you lose your card or require another, you can obtain one from an approved dealer. If a card is replaced, it will be necessary to take the vehicle **and all its cards** to an approved Dealer to initialise the system. You may use up to four cards per vehicle.

CARD

1



Driver's responsibility when parking or stopping the vehicle

Never leave an animal, child or adult who is not self-sufficient alone in your vehicle, even for a short time. They may pose a risk to themselves or to others by starting the engine, activating equipment such as the electric windows or by locking the doors. Also, in hot and/or sunny weather, please remember that the temperature inside the passenger compartment increases very quickly.

RISK OF DEATH OR SERIOUS INJURY.

"Hands-free" card

Use



42600

There are two ways to lock/unlock the vehicle:

- the card in "hands-free" mode;
- the card in remote control mode.



Do not store the card anywhere it may come into contact with other electronic equipment (computer, phone etc.) as this could hinder its operation.

Using the card in hands-free mode

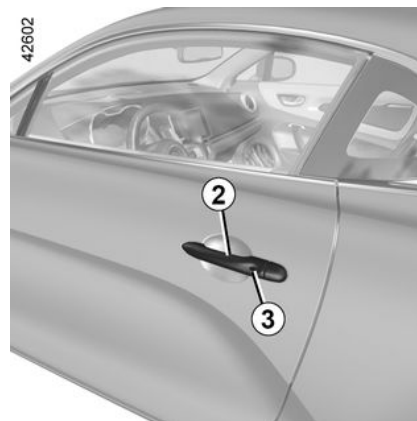

Unlocking the vehicle

With the card in zone **1** and the vehicle locked, press button **3** on the handle **2** of one of the front doors: the vehicle is unlocked.

Press button **4** or button **5** to open the luggage compartment and unlock the other opening elements.

Unlocking is indicated by **one flash** of the hazard warning lights and the indicator lights.

CARD

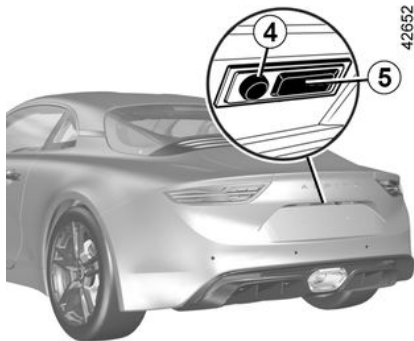

Note: the vehicle cannot be locked again for three seconds after unlocking by pressing button **3** as the locking is inhibited.



After locking/unlocking the vehicle using the buttons on the card, "hands-free"

locking and unlocking is deactivated.

To reactivate the "hands-free" mode, restart the vehicle.

Interference

Interference by factors in the immediate vicinity (external

installations or the use of equipment operating on the same frequency as the card) may disrupt its operation.

Special features of the unlocking system

After three days of inactivity, unlocking by pressing button **3** or button **4** is deactivated. Press the remote control to unlock the vehicle and to reactivate the mode.



Locking the vehicle

With the card in zone **1** and the doors and luggage compartment closed, press button **3** on one of the front door handles or button **4** on the luggage compartment door. The vehicle will lock. The indicator lights and hazard

warning lights **flash twice** to indicate that the doors have locked.

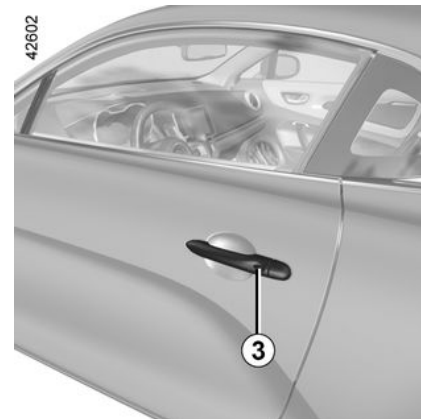

Special features of the locking system

After locking by pressing button **3** or button **4**, you must wait for approximately three seconds to be able to unlock the vehicle again. During these three seconds, the door handles can be tried to make sure that the vehicle is locked properly.

CARD

1

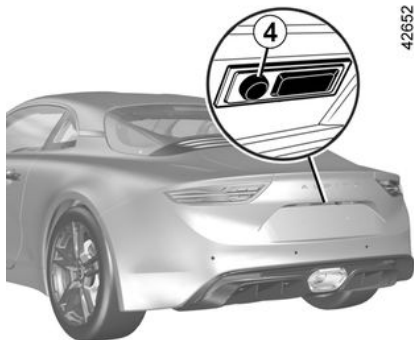

42652



42653

If an opening element (door, luggage compartment or bonnet) is open or incorrectly closed, when locking by pressing button **3** or button **4**, the vehicle will lock and then quickly unlock **without flashing** of the hazard warning lights and direction indicator lights.

The vehicle cannot be locked if the card is within zone **6**.

"Hands-free" card non-detection alarm

With the engine on, if you open and close a door and the card is no longer in zone **6**, the "Keycard Not Detected" message is displayed on the instrument panel for approximately 15 seconds and a beep sounds to warn you.

The warning disappears when the card is again in zone **6**.

Using the card as a remote control



26787

Unlocking with the card

Press the button **7**.

Unlocking is indicated by **one flash** of the hazard warning lights and the direction indicator lights.



The card buttons are deactivated when the engine is running.

Locking using the card

With the doors, luggage compartment and bonnet closed, press button **8**: the vehicle locks.

CARD

The indicator lights and hazard warning lights **flash twice** to indicate that the doors have locked.

Note: the maximum distance from which the vehicle can be locked depends on the surroundings.



Never leave your vehicle with the card inside.



Recommendations

To prevent premature discharging of the vehicle battery during standby, maintain the card at least five metres from your vehicle.



Driver's responsibility when parking or stopping the vehicle

Never leave an animal, child or adult who is not self-sufficient alone in your vehicle, even for a short time. They may pose a risk to themselves or to others by starting the engine, activating equipment such as the electric windows or by locking the doors. Also, in hot and/or sunny weather, please remember that the temperature inside the passenger compartment increases very quickly.

RISK OF DEATH OR SERIOUS INJURY.

Deadlocking



If the vehicle is equipped with a deadlocking function, this allows you to lock the opening elements and to prevent the doors from being unlocked using the interior handles (for example, by breaking the window and then trying to open the door from the inside).



Never use deadlocking if someone is still inside the vehicle.

CARD

1

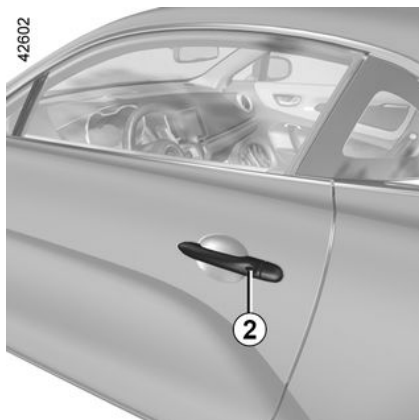

Vehicle with card

Press button **1** twice in quick succession.

Vehicle with "hands-free" card

With the vehicle unlocked, you can also press twice, in quick succession, on button **2** of the driver's door and passenger's door or on button **3** of the luggage compartment.

In both cases, the hazard warning lights and direction indicator lights give **two slow flashes and three quick flashes** to indicate locking.

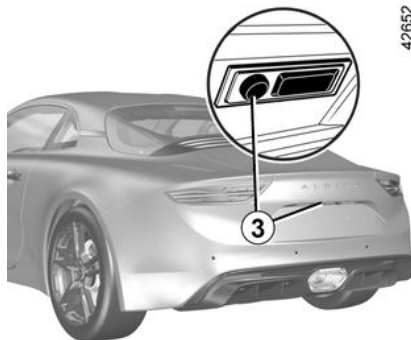

Special note: deadlocking is not possible if the hazard warning lights or the side lights are lit.

KEY, REMOTE CONTROL

Use

Unlocking the doors and tailgate

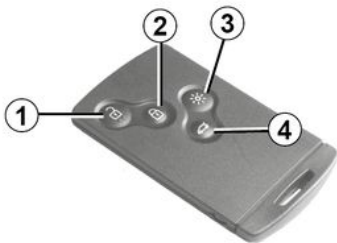

Press the button **1**.

The hazard warning lights **flash once** to indicate that the doors have been unlocked.

When only the driver's door is unlocked:

- pressing button **1** unlocks only the driver's door and the fuel filler flap;
- pressing button **1** twice unlocks the doors and the luggage compartment.

Locking the doors and tailgate

Press the locking button **2**. The hazard warning lights **flash twice to indicate that the vehicle is locked. If one of the opening elements (door, luggage compartment, bonnet) is open or not properly shut, or if a card is still in the reader, the opening elements lock then quickly unlock and the hazard warning lights do not flash.**



The card buttons are deactivated when the engine is running.

The flashing status of the hazard warning lights informs you of the vehicle status:

- **one flash** indicates that the vehicle is completely unlocked;
- **two flashes** indicate that the vehicle is completely locked.



If the vehicle has been unlocked but neither the doors or tailgate are open, it locks again automatically after two minutes.

Unlocking/locking the rear luggage compartment only

Press button **4** to unlock/lock the rear luggage compartment.

card not detected alarm

If a door is opened while the engine is on and the card is not in the reader, the "Keycard Not Detected" message will be displayed, accompanied by a beep, to warn you. The warning disappears when the card is inserted in the reader again.

"Remote lighting" function

Press button **3** to switch on the exterior lights and interior lighting for approximately 30 seconds. This can be used, for example, to identify the vehicle from a distance when parked in a car park.

Note: press button **3** again to switch off the lighting.

DOORS AND OPENING ELEMENTS

1

Opening and closing the doors

Opening from the outside

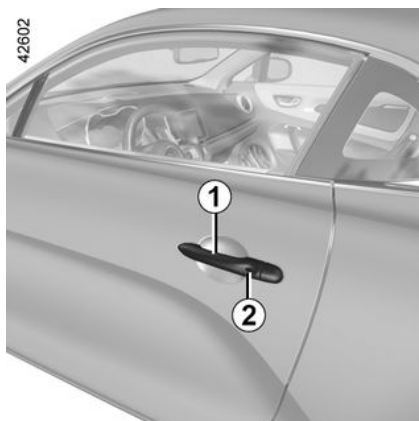

Front doors

With the doors unlocked, pull the handle **1**.

Special feature of the "hands-free" card

With the doors locked, press button **2** on the handle **1** of one of the front doors and pull it towards you.

Opening from the inside

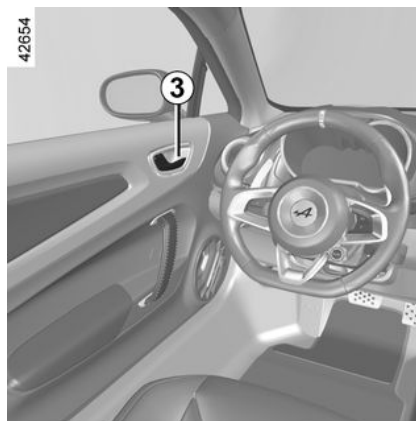

Pull the handle **3**.



Door locking is accompanied by the windows closing.

Risk of serious injury.



As a safety precaution, the doors should only be opened/closed when the vehicle is stationary.

Door or luggage compartment lid open buzzer

If an opening element (door, luggage compartment or bonnet) is open or

poorly closed, the  warning light appears on the instrument panel. As soon as the vehicle reaches approximately 6 mph (10 km/h), the "WARNING: Boot Open" or "WARNING: Door Open" message (depending on the opening element) appears on the instrument panel accompanied by a beep.

DOORS AND OPENING ELEMENTS

 Every time one of the doors is opened, the window lowers by a few centimetres to facilitate door movement. The window closes as soon as the door is closed.

If there is any ice or snow preventing the window from lowering when one of the doors is opened, this ice or snow must be removed to free the window before the door is closed.

If you need to disconnect the battery (breakdown etc.), lower the windows to make handling the doors easier whilst the battery is disconnected.

Lights-on reminder audible alarm

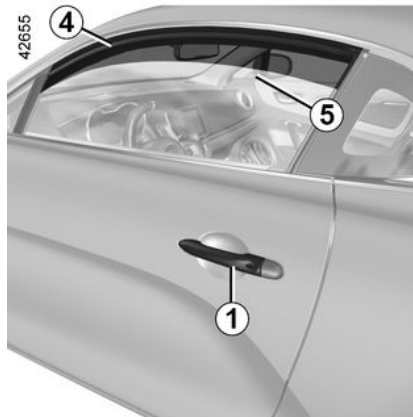

If you have switched off the ignition and left the lights switched on, a warning buzzer will sound when a door is opened.

Card reminder buzzer

When the driver's door is opened a beep will sound if the card is left in the reader and the "Remove card" message appears on the instrument panel, accompanied by a beep.

Operating faults

In the event of a battery fault:

- **to open the door:** pull the handle **1** then open the door with care to avoid damaging the seal **4**;
- **to close the door:** press the top of the window (zone **5**) while holding the door using the handle **1** to enable it to pass under seal **4**, then close the door gently.

In the event of a fault with the electric windows:

The window does not lower when the door is opened and does not close when the door is closed. In this case, pull the electric window button **six times** in succession to close the window completely.

To close the door, proceed as described in the section entitled "In the event of a battery fault".



Do not close the door by holding the window. Make sure you do not place your fingers too high up in zone **5**.

Risk of injury.

DOORS AND OPENING ELEMENTS

1



Driver's responsibility when parking or stopping the vehicle

Never leave an animal, child or adult who is not self-sufficient alone in your vehicle, even for a short time. They may pose a risk to themselves or to others by starting the engine, activating equipment such as the electric windows or by locking the doors. Also, in hot and/or sunny weather, please remember that the temperature inside the passenger compartment increases very quickly.

RISK OF DEATH OR SERIOUS INJURY.

Locking, unlocking the opening elements

Locking/unlocking the doors from the outside

This is done using the card: refer to the information on "Cards" in Section 1.

In certain cases, the card may not work:

- when the card battery is drained, flat battery, etc.
- use of appliances operating on the same frequency as the card (mobile phone, etc.);
- the vehicle is located in a high electromagnetic radiation zone.

It is then possible:

- to use the card's built-in key to unlock the front left-hand door;
- to lock each of the doors manually;
- to use the interior door locking/unlocking control (refer to the following pages).

Using the key integrated in the card

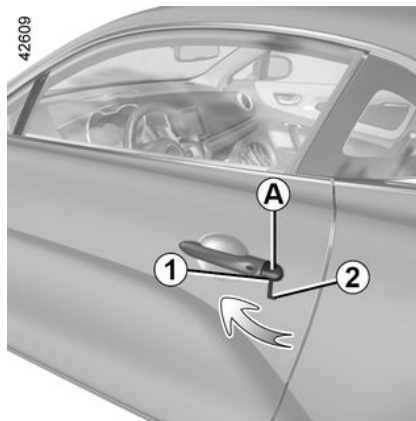

- Remove the cover **A** from the left-hand door by inserting the end of the key **2** into the notch **1**;
- Move it upwards to remove the cover **A**;
- insert the key **2** into the lock and then lock or unlock the front left-hand door.

Locking the doors manually



With the door open, pivot the bolt **3** (using the end of the built-in key) and close the door.

This means that the door is then locked from the outside.

The doors may then only be opened from the inside or by using the key in the front left-hand door.

DOORS AND OPENING ELEMENTS

Interior locking/unlocking door control

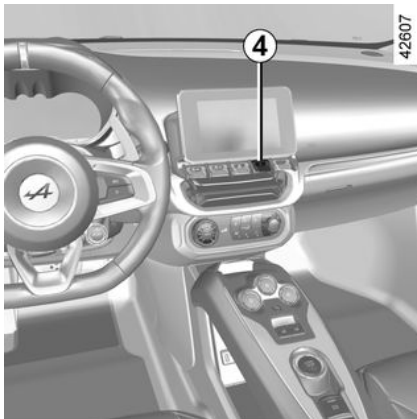

Switch **4** controls the doors, boot and, depending on the vehicle, the fuel filler flap simultaneously.

If one of the opening elements (door, luggage compartment or bonnet) is left open or improperly closed, they lock and then quickly unlock.

If transporting an object which requires the luggage compartment to be left open, you can still lock other opening elements: **with the engine off**, press and hold switch **4** for at least five seconds to lock the other opening elements.

Locking the doors without the card

For example, in the event of a discharged battery or the card temporarily not working, etc.

With the ignition off and a door or the luggage compartment open, press and hold switch **4**.

When the door is closed, all the doors and tailgate will be locked.

Unlocking the vehicle from the outside is only possible with the card in the vehicle's access zone or using the key integrated into the card.

 After locking/unlocking the vehicle using the buttons on the card, the "hands-free" locking and unlocking is deactivated. To reactivate the "hands-free" mode, restart the vehicle.

Door and tailgate status indicator

When the ignition is on, the indicator light integrated in switch **4** informs you of the locking status of the opening elements:

– when the warning light is on, the doors and luggage compartment door are locked;

– indicator light off, the doors and tailgate are unlocked.

When you lock the doors, the indicator light remains lit and then goes out.



Never leave your vehicle with the card inside.



Driver's responsibility

If you decide to keep the doors locked when you are driving, remember that it may be more difficult for those assisting you to gain access to the passenger compartment in the event of an emergency.

DOORS AND OPENING ELEMENTS

1

Automatic locking when driving

Operating principle

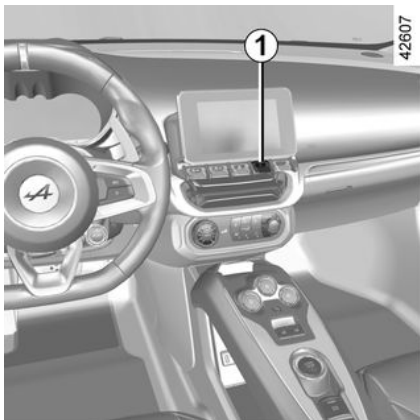

After the vehicle is started, the system automatically locks the doors when you reach approximately 6 mph (10 km/h).

The door can be unlocked:

- by pressing the door unlocking button **1**.
- by opening a door when stationary.

Note: if a door is opened/closed, it will automatically lock again when the vehicle reaches a speed of approximately 6 mph (10 km/h).

Activating/deactivating the function

With the engine running, press the button **1** for approximately five seconds until you hear a beep.

Operating faults

If you experience an operating fault (no automatic locking, the warning light integrated into the button **1** does not light up when trying to lock the opening elements, etc.). First check that the opening elements are properly closed. If they are properly closed, contact an approved dealer.



Driver's responsibility

If you decide to keep the doors locked when you are driving, remember that it may be more difficult for those assisting you to gain access to the passenger compartment in the event of an emergency.

FRONT SEATS

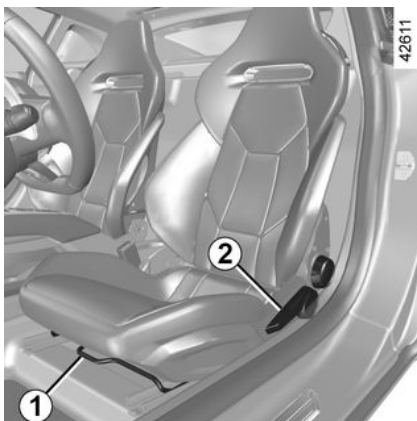

The presence and number of the adjustments depend on the vehicle and the type of the seat.

To move the seat forwards or back

Raise the handle **1** to unlock the seat. Release the handle at the desired position and make sure that it is locked.

To raise or lower the seat.

Move lever **2** as many times as necessary upwards or downwards.

 For vehicles not fitted with a seat height adjustment control, you must contact an Authorised Dealer to carry out this adjustment.

 After making adjustments, make sure that the seatbacks are correctly locked in place.

 For safety reasons, carry out any adjustments while the vehicle is stationary.

Nothing should be placed on the floor (area in front of the driver) as these objects may slide under the pedals during sudden braking manoeuvres, thus obstructing their use.

To tilt the seatback

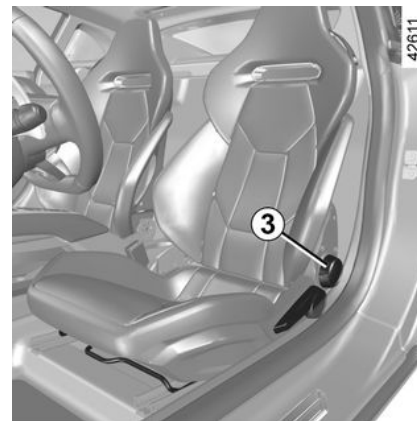

Turn the control knob **3** and tilt the seatback to the desired position.

 We would advise you not to recline the seatbacks too far to ensure that the effectiveness of the seat belts is not reduced.

FRONT SEATS

1

Heated seats



Ignition on:

- **the first time you press** the switch **4** for the seat concerned, the system is activated with the heating set to "High". Both of the built-in warning lights on the switch light up;
- **press the switch again** changes the heating to low. One integrated warning light is illuminated;
- **press for a third time** to turn the heating off.

Operating faults

When an operating fault is detected, the built-in warning lights on the switch **4** for the seat concerned will flash. Consult an approved dealer.

SEAT BELTS

Always wear your seat belt when travelling in your vehicle. You must also comply with the legislation of the particular country you are in.



Incorrectly adjusted or twisted seat belts may cause injuries in the event of an accident.

Use one seat belt per person, whether child or adult.

Even pregnant women should wear a seat belt. In this case, ensure that the lap belt is not exerting too much pressure on the abdomen, but do not allow any slack.

Before starting, first adjust your driving position, then ask all occupants to adjust their seat belts to ensure optimum protection.

Adjusting your driving position

- **Sit well back in your seat** (having removed your coat or jacket, etc.). This is essential to ensure that your back is positioned correctly;
- **adjust the distance between the seat and the pedals.** Your seat should be as far back as possible while still

- allowing you to fully depress the pedals. The seatback should be adjusted so that your arms are slightly bent when you hold the steering wheel;
- **adjust or, for vehicles not fitted with the adjustment control, have an Approved Dealer adjust the height of the seat. This adjustment allows you to select the seat position which offers you the best possible view;**
 - **adjust the position of the steering wheel.**

Adjusting the seat belts

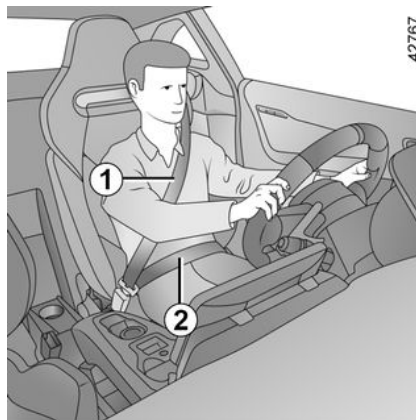

To ensure the correct adjustment and positioning of the seat belts on all seats:

- adjust the seats (seat position and seatback angle, if available);
- sit with your back firmly against the seatback;
- move the shoulder strap **1** as close as possible to the base of the neck without it actually resting against it (if necessary, adjust the height of the seat belt if possible) and make sure that the shoulder strap **1** is in contact with the shoulder;
- position the lap belt **2** so that it lies flat on the thighs and against the pelvis.

The seat belt must be worn as close to the body as possible. e.g. avoid wearing heavy clothing, keeping bulky objects under the belts, etc.

SEAT BELTS

1

Locking



Unwind the belt **slowly and smoothly** and ensure that the buckle **3** locks into the catch **5** (check that it is locked by pulling on the buckle **3**).

If the belt jams, allow it to return slightly before attempting to unwind it again.

If your seat belt is completely jammed, pull slowly, but firmly, so that just over 3 cm unwinds. Allow it to return slightly before attempting to unwind it again.

If there is still a problem, contact an approved dealer.



Driver's seat belt reminder and, depending on the vehicle,

passenger seat belt reminder

This appears on the instrument panel when the ignition is switched on if the driver's and/or passenger's seat belt (as long as the passenger seat is occupied) is not fastened.

Depending on the vehicle, if the seat is occupied and one of these seat belts is not fastened or becomes unfastened while the vehicle is moving at a speed over approximately 12 mph (20 km/h),

the warning light  flashes and a beep sounds for approximately 120 seconds.

Note: an object placed on the passenger seat may activate the warning light in some cases, depending on the vehicle.

Unlocking

Press the button **4** and the seat belt will be rewound by the inertia reel. Guide the belt.



- No modification must be made to the originally-fitted restraint system components (seat belts, seats and their mountings). For special operations (e.g. fitting child seats) please contact an approved dealer.
- Do not use devices which give any slack in the belts (e.g. clothes pegs, clips, etc.), as a seat belt which is worn too loosely risks causing injury in the event of an accident.
- Never wear the shoulder strap under your arm or behind your back.
- Never use the same belt for more than one person and never hold a baby or child on your lap with your seat belt around them.
- The belt should never be twisted.
- Following an accident, have the seat belts checked and replaced if necessary. Always replace your seat belts as soon as they show any signs of wear.

SEAT BELTS

- Make sure that the seat belt buckle is inserted into the appropriate catch.
- Ensure that no objects are placed in the area around the seat belt catch as they could prevent it from being properly secured.
- Make sure the seat belt catch is properly positioned (it should not be hidden away, crushed or flattened by people or objects).

ADDITIONAL SAFETY DEVICES

1

Methods of restraint in addition to the front seat belts

Depending on the vehicle, they may comprise:

- **front seat belt inertia reel pretensioners;**
- **chest force limiters;**
- **airbags driver and passenger front.**

These systems are designed to act independently or together when the vehicle is subjected to a frontal impact.

Depending on the severity of the impact, the system can cause:

- blocking of the seat belt;
- the seat belt inertia reel pretensioner which is triggered to correct seat belt slack;
- the airbags.

Pretensioners

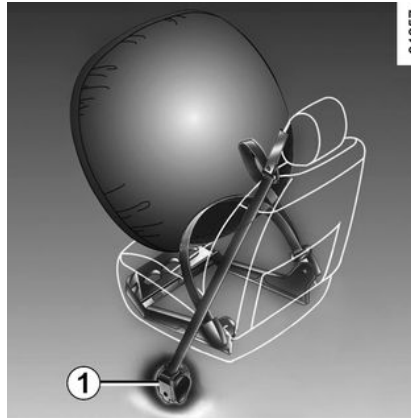

The pretensioners hold the seat belt against the body, holding the occupant more securely against the seat, thus increasing the seat belt's efficiency.

With the ignition on, following a significant frontal impact and depending on the severity of the impact, the system may trigger the seat belt inertia reel pretensioner **1** which instantly retracts the seat belt.



- Have the entire restraint system checked following an accident.
- No operation whatsoever is permitted on any part of the system (pretensioners, airbags, computers, wiring) and the system components must not be reused on any other vehicle, even if identical.
- Only qualified personnel from our Network may work on the pretensioners and airbags, otherwise the system may trigger accidentally and cause injury.
- The electrical trigger system may only be tested by a specially trained technician using special equipment.
- If scrapping your vehicle, contact an approved dealer for disposal of the gas generator of the pretensioners and airbags.

Load limiter

Above a certain severity of impact, this mechanism is used to limit the force of the belt against the body so that it is at an acceptable level.

ADDITIONAL SAFETY DEVICES

driver and passenger front Airbags

Fitted to the driver and passenger sides.

The presence of this equipment is indicated by the "Airbag" mark on the steering wheel, the dashboard (in the area of the airbag **A**) and, depending on the vehicle, a label on the lower section of the windscreen.

Each airbag system consists of:

- an airbag and gas generator fitted on the steering wheel for the driver and in the dashboard for the front passenger;
- an electronic unit for monitoring the system controlling the gas generator electrical trigger;
- a single  warning light on the instrument panel.

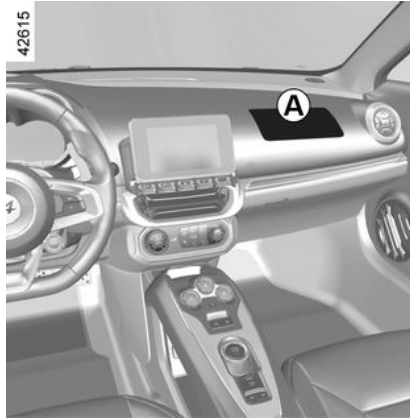

The airbag system uses pyrotechnic principles. This explains why, when the airbag inflates, it will generate heat, produce smoke (this does not mean that a fire is about to start) and sound like a detonation. In a situation where an airbag deployment is required, it will inflate immediately and this may cause some minor, superficial grazing to the skin or other problems.

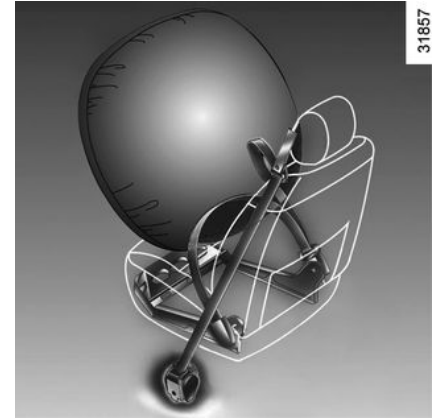

Operation

This system is only operational when the ignition is switched on.

In a severe **frontal** impact, the airbags inflate rapidly, cushioning the impact of the driver's head and chest against the steering wheel and of the front passenger against the dashboard. The airbags then deflate immediately so that the passengers are not in any way prevented from leaving the vehicle.

ADDITIONAL SAFETY DEVICES

1

Operating faults



The warning light 2  will light up on the instrument panel when the ignition is switched on and then go out after a few seconds.

If it does not light up when the ignition is switched on, or if it lights up when the engine is running, this indicates a fault in the system.

Contact your approved Dealer as soon as possible;

Your protection will be reduced until this fault is rectified.

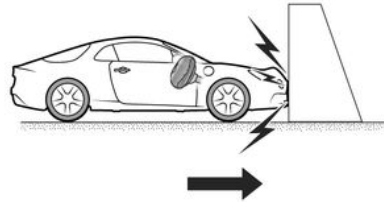

The following cases trigger the pretensioners or airbags .

In a frontal impact against a rigid (non-deformable) surface at an impact speed equal to or greater than 16 mph (25 km/h).

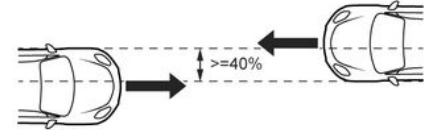

In the event of a frontal impact with another vehicle of an equivalent or higher category, with an impact area equal to or greater than 40%, where the speed of both vehicles is equal to or greater than 25 mph (40 km/h).

ADDITIONAL SAFETY DEVICES

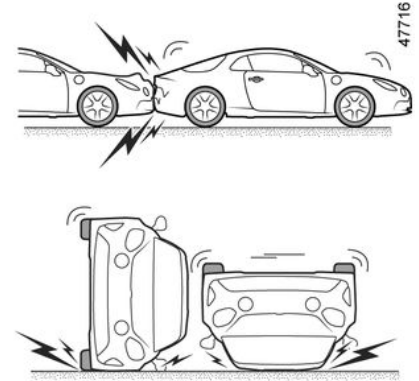
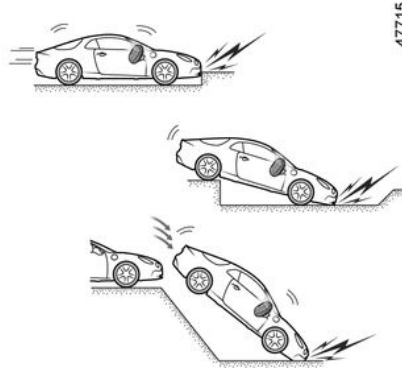
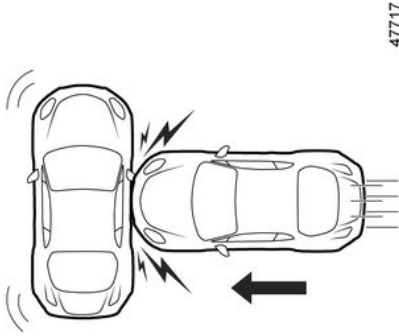

In a side impact with another vehicle of an equivalent or higher category, at an impact speed equal to or greater than 31 mph (50 km/h).

The pretensioners or airbags may be triggered in the following cases:

- an impact underneath the vehicle (e.g. pavement kerb);
- potholes;
- a fall or a hard landing;
- stones;
- ...

In the following cases, the pretensioners or airbags might not be triggered:

- a rear impact, however severe;
- the vehicle overturning;

ADDITIONAL SAFETY DEVICES

1

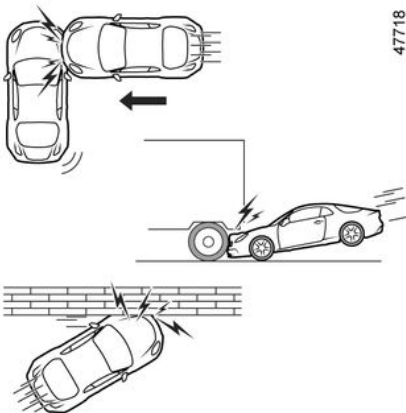

- side impact at the front or rear of the vehicle;
- frontal impact, underneath the tail of a lorry;
- frontal impact against an obstacle with a sharp angle;
- ...

All of the following warnings are intended to ensure that the airbag is not obstructed in any way when it is inflated and also to prevent the risk of serious injuries caused by items which may be projected when it inflates.



Warnings in relation to the driver's airbag

- Do not modify the steering wheel or the boss.
- Do not cover the steering wheel boss under any circumstances.
- Do not attach any objects (badge, logo, watch, telephone cradle, etc.) to the steering wheel boss.
- The steering wheel must not be removed (except by qualified personnel from our Network).
- Do not sit too close to the steering wheel when driving: sit with your arms slightly bent (see "Adjusting your driving position" in Section 1). This will allow sufficient space for the airbag to deploy correctly and be fully effective.

Warnings in relation to the passenger's airbag

- Do not attach or glue any objects (badge, logo, clock, telephone holder, etc.) to the dashboard over or near the airbag.

- Do not place anything between the dashboard and the passenger (animal, umbrella, walking stick, parcels, etc.).
- The passenger must not put his or her feet on the dashboard or seat as there is a risk that serious injuries may be sustained. As a general rule, parts of the body should be kept away from the dashboard (knees, hands, head, etc.).
- the devices in addition to the front passenger seat belt should be reactivated as soon as a child seat is removed, to ensure the protection of the passenger in the event of an impact.

A REAR-FACING CHILD SEAT MUST NOT BE FITTED TO THE FRONT PASSENGER SEAT UNLESS THE RESTRAINT SYSTEMS IN ADDITION TO THE FRONT PASSENGER SEATBELT ARE DEACTIVATED

(refer to the "Child Safety: deactivation, activation of the front passenger airbag" in Section 1).

ADDITIONAL SAFETY DEVICES

Additional methods of restraint

All of the following warnings are intended to ensure that the airbag is not obstructed in any way when it is inflated and also to prevent the risk of serious injuries caused by items which may be projected when it inflates.



The airbag is designed to complement the action of the seat belt.

Both the airbag and the seat belt are integral parts of the same protection system. It is therefore essential to wear seat belts at all times. If seat belts are not worn, the occupants are exposed to the risk of serious injury in the event of an accident. It may also increase the risk of minor superficial injuries occurring when the airbag is deployed, although such minor injuries are always possible with airbags. If the vehicle should overturn or suffer a rear impact, however severe, the pretensioners and airbags are not always triggered. Shocks to the underbody of the vehicle, from pavements, potholes, stones etc. can all trigger these systems.

– Any work or modification on any part of the airbag (airbags, pretensioners, computer, wiring harness, etc.) **is strictly prohibited** (except by qualified personnel from the network).

– To ensure that the system is in good working order and to avoid accidental triggering of the system which may cause injury, only qualified personnel from the network may work on an airbag system.

– As a safety precaution, have the airbag system checked if your vehicle has been involved in an accident, or is stolen or broken into.

– When selling or lending the vehicle, inform the new purchaser of these conditions when handing over this vehicle user manual.

– When scrapping your vehicle, contact your approved dealer for disposal of the gas generator(s).

CHILD SAFETY

1

General information

Carrying children

Please ensure that you comply with the legislation of your country.

Children, and adults, must be correctly seated and strapped in for all journeys. The children being carried in your vehicle are your responsibility.

A child is not a miniature adult. Children are at risk of specific injuries as their muscles and bones have not yet finished growing. The seat belt alone would not provide suitable protection. Use an approved child seat and ensure you use it correctly.



A collision at 31 mph (50 km/h) is the same as falling a distance of 10 metres. Transporting a child without a restraint is the equivalent of allowing him or her to play on a fourth-floor balcony without railings. Never travel with a child held in your arms. In the event of an accident, you will not be able to keep hold of the child, even if you yourself are wearing a seat belt. If your vehicle has been involved in a road accident, replace the child seat and have the seat belts checked.



Driver's responsibility when parking or stopping the vehicle

Never leave an animal, child or adult who is not self-sufficient alone in your vehicle, even for a short time. They may pose a risk to themselves or to others by starting the engine, activating equipment such as the electric windows or by locking the doors. Also, in hot and/or sunny weather, please remember that the temperature inside the passenger compartment increases very quickly.

RISK OF DEATH OR SERIOUS INJURY.

Using a child seat

The level of protection offered by the child seat depends on its ability to restrain your child and on its installation. Incorrect installation compromises the protection it offers the child in the event of harsh braking or an impact.

Before purchasing a child seat, check that it complies with the regulations for

CHILD SAFETY

the country you are in and that it can be fitted in your vehicle. Consult an approved Dealer to find out which seats are recommended for your vehicle.

The regulations on transporting children are specific to each country. The use of a child seat during transport depends on the age and/or the size and/or weight of the child. For children who do not need to be transported in a child seat, make sure that the seat belt is correctly adjusted and fastened. In all cases, you must comply with the regulations of the particular country you are in.

Before fitting a child seat, read the manual and respect its instructions. If you experience any difficulties during installation, contact the manufacturer of the equipment. Keep the instructions with the seat.



Set a good example by always fastening your seat belt and teaching your child:

- to strap themselves in correctly;
- to always get in and out of the car at the kerb, away from busy traffic.

Do not use a second-hand child seat or one without an instruction manual.

Check that there are no objects in the vicinity of the child seat which could impede its operation.



Never leave a child unattended in the vehicle.

Check that your child is always strapped in and that the belt or safety harness used is correctly set and adjusted. Avoid wearing bulky clothing which could cause the belts to slacken. For more information, please refer to the information on "Seat belts" in Section 1.

Never let your child put their head or arms out of the window. Check that the child is in the correct position for the entire journey, especially if asleep.

CHILD SAFETY

1 Choosing a child seat



31235

Rear-facing child seats

A baby's head is, proportionally, heavier than that of an adult and its neck is very fragile. Transport the child in this position as long as possible (until the age of 2 at the very least). It supports both the head and the neck.

Choose a bucket type seat for best side protection and change it as soon as the child's head is higher than the shell.



38824

Forward-facing child seats

Up to 18 kg or 4 years, the child may travel on a forward-facing seat.

Choose your seat according to the child's size: their head and abdomen are the areas which must be most protected. A forward-facing child seat which is firmly attached to the vehicle will reduce the risk of impact to the head. Ensure your child travels in a forward-facing seat with a harness for as long as their size permits.

Choose a bucket type seat for optimum side protection.



31234

Booster cushions

From 15 kg or 4 years, the child can travel using a booster seat, which will enable the seat belt to be adapted to suit his size and shape. The booster seat cushion must be fitted with guides to position the seat belt on the child's thighs rather than the stomach. It is recommended that you use a seatback which can be adjusted in terms of height to position the seat belt in the centre of the shoulder. It must never rest on the neck or on the arm.

Choose a bucket type seat for optimum side protection.

Child seat mounting

Attachment via the seat belt

CHILD SAFETY

The seat belt must be adjusted in order to ensure it works in the event of sudden braking or impact.

Ensure that the strap paths indicated by the child seat manufacturer are observed.

Always check that the seat belt is correctly fastened by pulling it up, then pulling it out fully whilst pressing on the child seat.

Check that the seat is correctly held by moving it from side to side and back to front: the seat should remain firmly fixed.

Check that the child seat has not been installed at an angle and that it is not resting against a window.



Do not use the child seat if it risks unfastening the seat belt restraining it: the base of the seat must not rest on the buckle and/or catch of the seat belt.



The seat belt must never be twisted or the tension relieved. Never pass the shoulder strap under the arm or behind the back.

Check that the seat belt has not been damaged by sharp edges. If the seat belt does not operate normally, it will not protect the child. Consult an approved dealer. Do not use this seat until the seat belt has been repaired.



Check that the seatback of the forward-facing child seat is in contact with the seatback of the vehicle seat. In this case, the child seat may not always rest on the seat base of the vehicle seat.



No modifications may be made to the originally fitted restraint system components (seat belts, seats and their mountings).

Fitting a child seat, general information

Some seats are not suitable for fitting child seats. The diagram on the following page shows you how to attach a child seat.

The types of child seats indicated may not be available. Before using a different child seat, check with the manufacturer that it can be fitted.



Make sure the child seat or the child's feet do not prevent the front seat from locking correctly.

Refer to the information on the "Front seat" in Section 1. Check that when installing the child seat in the vehicle it is not at risk of coming loose from its base. Always attach the child seat to the vehicle even if it is not in use so that it does not come loose under harsh braking or impact.

In the front seat

The laws concerning children travelling in the front passenger seat differ in every country. Consult the legislation in

CHILD SAFETY

1

force and follow the indications on the diagram on the following page.

Before fitting a child seat in this seat (if authorised):

- lower the seat belt as far as possible;
- move the seat as far back as possible;
- gently tilt the seatback away from the vertical position (approximately 25°);
- on equipped vehicles, raise the seat base as far as possible.

After installing the child seat, you can move the vehicle seat if necessary. For a rear-facing child seat, do not let it touch the dashboard or move it to the furthest forward position.

Do not change other settings after installing the child seat.



RISK OF DEATH OR SERIOUS INJURY:

before installing a rear-facing child seat in the front passenger seat, make sure that the airbag has been deactivated (refer to the information on "Child safety: front passenger airbag deactivation/activation" in Section 1).

CHILD SEATS

1

Attachment by seat belt

The table below summarises the information already shown on the diagram on the following pages, to ensure the applicable regulations are respected.

Type of child seat	Weight of the child	Front passenger seat			
		With airbag deactivated		With airbag activated	
		With seat adjustment (3)	Without seat adjustment (3)	With seat adjustment (3)	Without seat adjustment (3)
Carrycot fitted across the vehicle Group 0	< 10 kg	X	X	X	X
Rear-facing shell seat Groups 0 or 0 +	< 10 kg and < 13 kg	U (1) (2)	X	X	X
Shell seat/rear-facing seat Groups 0+ and 1	< to 13 kg and 9 to 18 kg	U (1) (2)	X	X	X
Forward-facing seat Group 1	9 to 18 kg	X	X	U (2)	X
Booster seat Groups 2 and 3	15 to 25 kg and 22 to 36 kg	X	X	U (2)	X

CHILD SEATS



(1) RISK OF DEATH OR SERIOUS INJURY: before installing a rear-facing child seat in the front passenger seat, make sure that the airbag has been deactivated (refer to the information on "Child safety: front passenger airbag deactivation, activation" in Section 1).

X= Seat not suitable for fitting child seats of this type.

U= Seat allowing a child seat with "Universal" approval to be attached by seat belt: check that it can be fitted correctly.

(2) Raise the seat to the maximum and position it as far back as possible, tilting the seatback slightly (approximately 25°).

(3) The front passenger seat must be fitted with a control to move the seat forwards or backwards and a control to raise or lower the seat base in order to fit a child seat.

CHILD SEATS

1

Visual installation for vehicles with seat adjustment

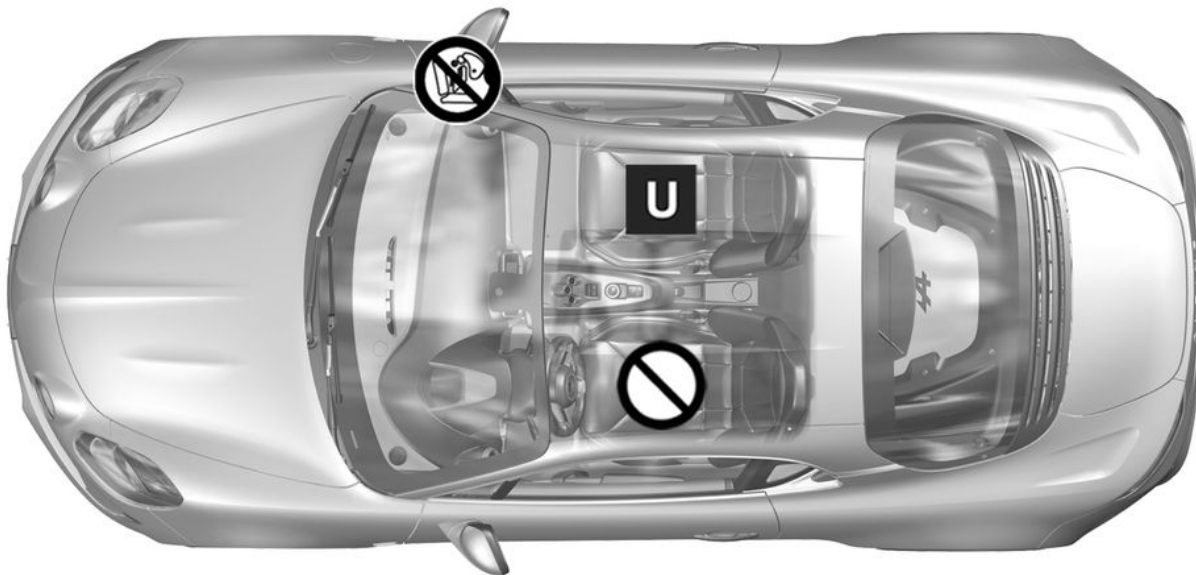

42621



RISK OF DEATH OR SERIOUS INJURY: before installing a rear-facing child seat in the front passenger seat, make sure that the airbag has been deactivated (refer to the information on "Child safety: front passenger airbag deactivation/activation" in Section 1).

CHILD SEATS



Using a child safety system which is not approved for this vehicle will not properly protect the baby or child. They risk serious or even fatal injury.



Check the status of the airbag before fitting a child seat or allowing a passenger to use the seat.



Seat not suitable for fitting child seats.



Seat which allows a child seat with "Universal" approval to be attached by a seat belt.



Check that your child is always strapped in and that the belt or safety harness used is correctly set and adjusted. For more information, please refer to the information on "Seat belts" in Section 1. If necessary, adjust the seat position accordingly.

CHILD SEATS

1

Visual installation for vehicles without seat adjustment



42620



RISK OF DEATH OR SERIOUS INJURY: before installing a rear-facing child seat in the front passenger seat, make sure that the airbag has been deactivated (refer to the information on "Child safety: front passenger airbag deactivation/activation" in Section 1).

CHILD SEATS



Using a child safety system which is not approved for this vehicle will not properly protect the baby or child. They risk serious or even fatal injury.



Check the status of the airbag before fitting a child seat or allowing a passenger to use the seat.



Seat not suitable for fitting child seats.



Check that your child is always attached and that the harness or seat belt is correctly adjusted (see the information on "Seat belts" in Section 1).
If necessary, adjust the seat position accordingly.

CHILD SAFETY: DEACTIVATING, ACTIVATING THE FRONT PASSENGER AIRBAG

1

Front passenger airbag deactivation

(on equipped vehicles)

Before installing a child seat on the front passenger seat:

- check that the child seat can be installed on this seat;
- you **must** deactivate the airbag when using a rear-facing child seat.



DANGER

As the operation of the front passenger airbag is not compatible with the positioning of rear-facing child seat, **NEVER fit a rear-facing child restraint system in a seat protected by an ACTIVATED front AIRBAG . This could lead to the CHILD'S DEATH or SERIOUS INJURY.**

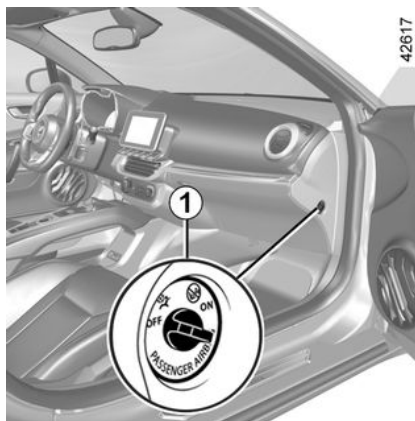

42617

To deactivate the airbag : with the vehicle stationary and the ignition switched off, push and turn lock 1 to the OFF position.

When the ignition is switched on, you

must check that the  warning light is illuminated on the display 2.

This light remains continuously lit to let you know that you can fit a child seat.

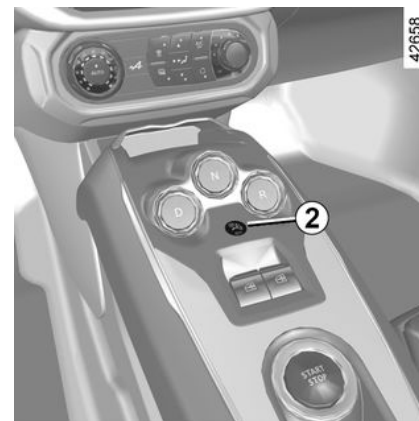

42658



The activation or deactivation of the front passenger airbag must be done **while the vehicle is stationary and the ignition is switched off.**

If it is interfered with when the vehicle is being driven, indicator

lights  and  will come on.

Switch the ignition off then on again to reset the airbag in accordance with the lock position.

CHILD SAFETY: DEACTIVATING, ACTIVATING THE FRONT PASSENGER AIRBAG

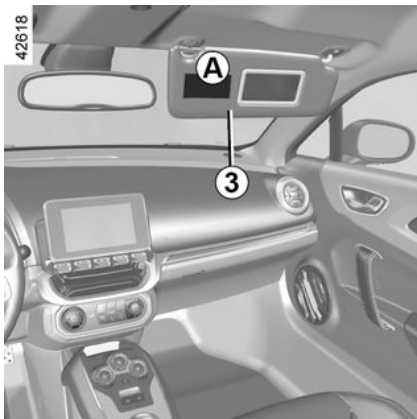

DANGER

As the operation of the front passenger airbag is not compatible with the positioning of rear-facing child seat, **NEVER fit a rear-facing child restraint system in a seat protected by an ACTIVATED front AIRBAG . This could lead to the CHILD'S DEATH or SERIOUS INJURY.**

58035



The markings on the dashboard and the labels **A** on each side of the passenger sun visor **3** (see example of label above) are provided to remind you of these instructions.

Activation of the front passenger airbag

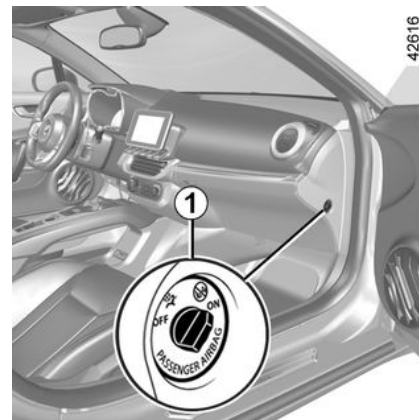

You must reactivate the airbag as soon as you remove the child seat from the front passenger seat to ensure the protection of the front passenger in the event of an impact.

CHILD SAFETY: DEACTIVATING, ACTIVATING THE FRONT PASSENGER AIRBAG

1



To reactivate the airbag : with the vehicle stationary and the ignition switched off, push and turn the lock **1** to the ON position.

When the ignition is switched on, you

must check that the  warning light is switched off on the display **2**.

The front passenger airbag is activated.

Operating faults

It is prohibited to fit a rear-facing child seat to the front passenger seat if the front passenger airbag activation/deactivation system is faulty.

Allowing any other passenger to sit in that seat is not recommended.



Contact your approved Dealer as soon as possible;



The activation or deactivation of the front passenger airbag must be done **while the**

vehicle is stationary and the ignition is switched off.

If it is interfered with when the vehicle is being driven, indicator

lights  and  will come on.

Switch the ignition off then on again to reset the airbag in accordance with the lock position.

DRIVING POSITION

1 Driving position: left-hand drive

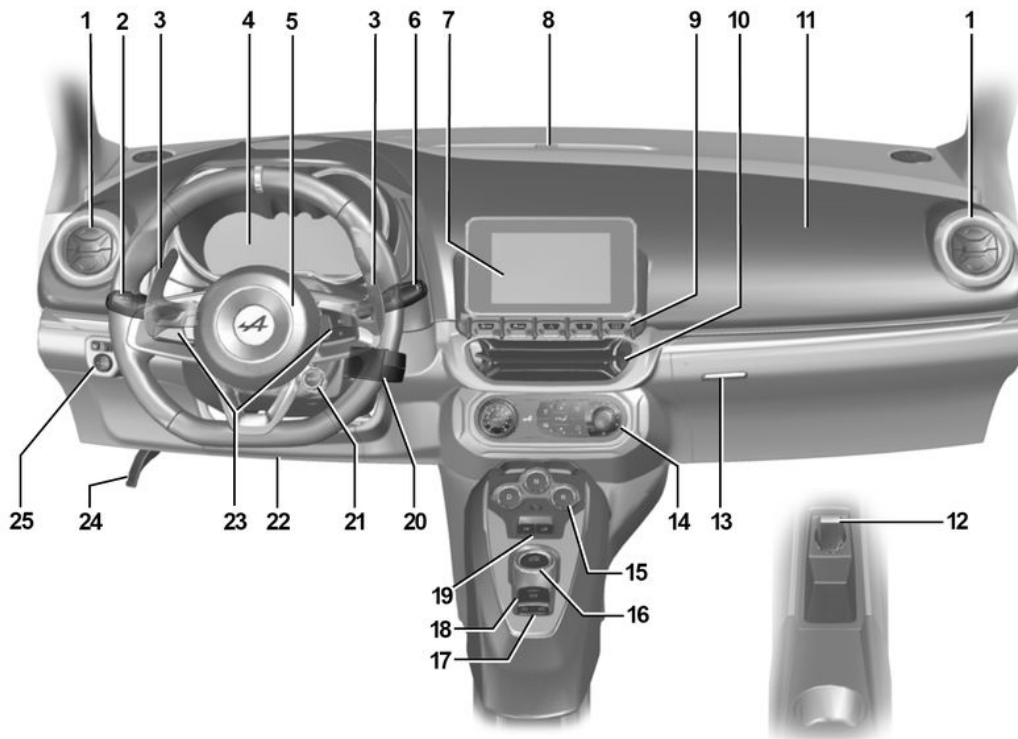

57595

DRIVING POSITION

The fittings described below DEPEND ON THE VEHICLE VERSION AND COUNTRY.

1. Side air vents.
2. Stalk for:
 - direction indicator lights;
 - exterior lights;
 - rear fog lights.
3. Gear change paddles.
4. Instrument panel.
5. Driver airbag and horn location.
6. Stalk for:
 - windscreen and rear screen wash/wipe;
 - trip computer and warning system information readout.
7. Multimedia screen.
8. Windscreen demister outlet.
9. Controls for:
 - activating/deactivating the Stop and Start function;
 - disabling the ESC and traction control functions;
 - hazard warning lights;
 - door central locking;
 - starting/stopping the multimedia system.
10. Centre air vent.
11. Passenger airbag location.
12. Cigarette lighter/accessories socket.
13. ALPINE card reader. Depending on the vehicle, this is located behind a cover (refer to "Starting, stopping the engine" in Section 2).
14. Heating or air conditioning controls.
15. Selection controls R, N, D.
16. Engine start/stop button.
17. Cruise control/speed limiter main control.
18. Electronic parking brake control.
19. Electric window control.
20. Multimedia equipment steering column control.
21. Choice of driving mode control.
22. Control for adjusting steering wheel height and reach.
23. Cruise control/speed limiter controls.
24. Bonnet release control.
25. Door mirror adjustment control.

DRIVING POSITION

1

Driver's position, right-hand drive

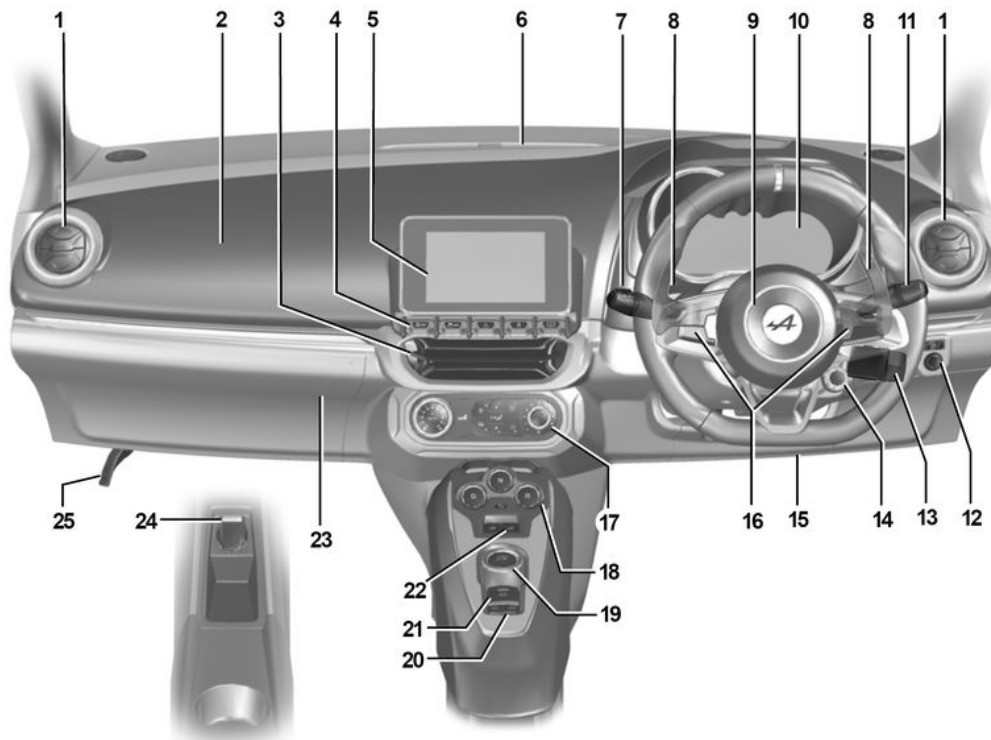

57564

DRIVING POSITION

The fittings described below DEPEND ON THE VEHICLE VERSION AND COUNTRY.

1. Side air vents.
2. Passenger airbag location.
3. Centre air vent.
4. Controls for:
 - activating/deactivating the Stop and Start function;
 - disabling the ESC and traction control functions;
 - hazard warning lights;
 - door central locking;
 - starting/stopping the multimedia system.
5. Multimedia screen.
6. Windscreen demister outlet.
7. Stalk for:
 - direction indicator lights;
 - exterior lights;
 - rear fog lights.
8. Gear change paddles.
9. Driver airbag and horn location.
10. Instrument panel.
11. Stalk for:
 - windscreen and rear screen wash/wipe;
 - trip computer and warning system information readout.
12. Door mirror adjustment control.
13. Multimedia equipment steering column control.
14. Choice of driving mode control.
15. Control for adjusting steering wheel height and reach.
16. Cruise control/speed limiter controls.
17. Heating or air conditioning controls.
18. Selection controls R, N, D.
19. Engine start/stop button.
20. Cruise control/speed limiter main control.
21. Electronic parking brake control.
22. Electric window control.
23. ALPINE card reader. Depending on the vehicle, this is located behind a cover (refer to "Starting, stopping the engine" in Section 2).
24. Cigarette lighter/accessories socket.
25. Bonnet release control.

TRIP COMPUTER

1

General information

Trip computer and warning system

A

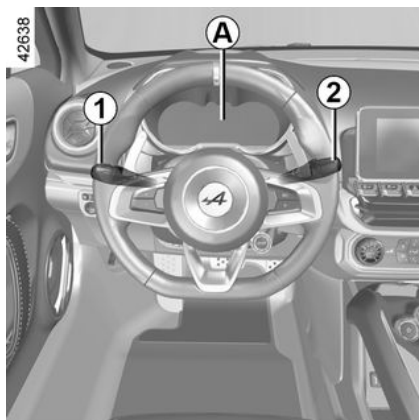

Briefly press button **4** or **5** on the stalk **2** repeatedly to scroll upwards or downwards through the following information (the display depends on the vehicle equipment and country).

– Multifunction screen: briefly press button **3** on the stalk **1** repeatedly to scroll horizontally through the information on this function (refer to "Multifunction screen" in Section 1);

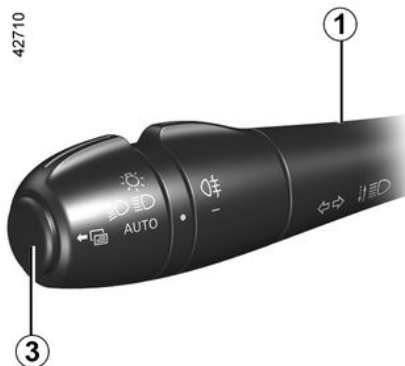

– trip settings: briefly press bouton **3** on the stalk **1** repeatedly to scroll horizontally through the following information:

- a) distance travelled;
- b) average fuel consumption;
- c) average speed;
- d) total mileage and trip mileage recorder;
- e) current fuel consumption;
- f) estimated range;
- g) distance before service;
- h) reset the tyre pressures;

– trip log, information message readout, operating and warning faults;

– adjust the brightness of the instrument panel;

– from the vehicle settings customisation menu (see "Vehicle settings customisation menu" in Section 1).

These functions are explained on the following pages.

TRIP COMPUTER

Resetting the journey parameters (reset button)

42710



With one of the trip settings selected, press and hold on button **3**, **4** or **5** until the display resets to zero.

Automatic resetting of the journey parameters

42635



Resetting occurs automatically when the maximum value of any of the parameters is exceeded.

Interpreting some of the values displayed after resetting

The values showing average fuel consumption, range and average speed will become more stable and reliable the further you travel after pressing the reset button.

For the first few miles after pressing the reset key you will notice that the range increases as you travel. This range takes into account the average fuel consumption since the last time

the reset button was pressed. Therefore, the average fuel consumption may decrease when:

- the vehicle stops accelerating;
- the engine reaches its operating temperature (if the engine was cold when the reset key was pressed);
- when driving from an urban area onto the open road.

TRIP COMPUTER







1

Journey settings

TRIP COMPUTER

The display of information shown below **DEPENDS ON THE VEHICLE EQUIPMENT AND COUNTRY.**





1

Examples of selections	Interpreting the display selected
 522 km	 a) distance travelled since the last reset.
 5.8 L/100	 b) average fuel consumption since the last reset. The value is displayed after having travelled at least 400 metres since the last reset.
 123.4 km/h	 c) average speed since the last reset. The value is displayed after driving 400 metres.

TRIP COMPUTER

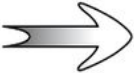

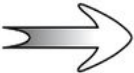
1

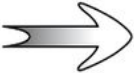
The display of information shown below **DEPENDS ON THE VEHICLE EQUIPMENT AND COUNTRY.**

Examples of selections	Interpreting the display selected
 101 778 km	 d) total mileage recorder.
 7.4 L/100	 e) current fuel consumption. This value is displayed after a speed of approximately 19 mph (30 km/h) is reached.
 541 km	 f) estimated range with remaining fuel. The value is displayed after driving 400 metres.

TRIP COMPUTER

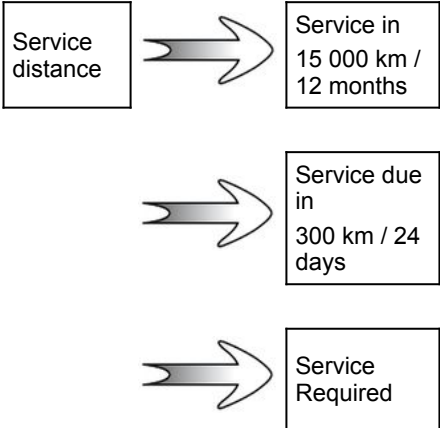
The display of information shown below **DEPENDS ON THE VEHICLE EQUIPMENT AND COUNTRY.**

Examples of selections	Interpreting the display selected
On-board computer with distance before next service message (continued)	
	<p>g) distance before service or oil change.</p> <p>Service distance</p> <p>With the ignition on, the engine not running and the display set to " Service Intervals ", press button 2 or 3 for approximately five seconds to display the distance before service (distance or time to the next service). When the distance or time value approaches its limit, there are several possible scenarios:</p> <ul style="list-style-type: none"> – mileage remaining less than 932 miles (1,500 km) or one month: the "Service due in" message is displayed accompanied by the nearest limit (distance or time); – if the range is 0 miles (0 km) or if the service date is reached: the "Service Required" message is displayed accompanied by the  warning light. <p>The vehicle requires a service as soon as possible.</p>
<p>Reset: to reset the distance before service, press button 3, 4 or 5 for approximately 10 seconds, until the distance before service appears and stays on.</p> <p>Note: if a service is performed without changing the engine oil, only the mileage before the next service should be reset. In the event of an oil change, both the distance before the next service and the next oil change should be reset.</p>	

TRIP COMPUTER

1

The display of information shown below **DEPENDS ON THE VEHICLE EQUIPMENT AND COUNTRY.**

Examples of selections	Interpreting the display selected
Tyre pressure: SET (press and hold)	 <p data-bbox="642 266 1368 348">h) reset the tyre pressures. Refer to the information on the "Tyre pressure monitoring system" in Section 2.</p>

TRIP COMPUTER

Information messages

These can help in the vehicle starting phase, or give information about a selection or a driving status.

Examples of information messages are given in the following pages.

TRIP COMPUTER

1

Examples of messages	Interpreting the display selected
<p>« Parking Brake ON »</p> <p>« Vehicle Checks in Progress »</p> <p>"Traction control deactivated"</p> <p>« Turn Steering Wheel + START »</p> <p>"Steering not locked"</p>	<p>Indicates that the parking brake has been applied.</p> <p>Displayed with the ignition on when the vehicle is running self-diagnostics.</p> <p>Indicates that you have deactivated the traction control function.</p> <p>Turn the steering wheel slightly whilst pressing the vehicle start button to unlock the steering column.</p> <p>Indicates that the steering column has not been locked.</p>
Examples of messages	Interpreting the display selected
<p>« Parking Brake ON »</p> <p>« Vehicle Checks in Progress »</p> <p>"Traction control deactivated"</p> <p>« Turn Steering Wheel + START »</p> <p>"Steering not locked"</p>	<p>Indicates that the parking brake has been applied.</p> <p>Displayed with the ignition on when the vehicle is running self-diagnostics.</p> <p>Indicates that you have deactivated the traction control function.</p> <p>Turn the steering wheel slightly whilst pressing the vehicle start button to unlock the steering column.</p> <p>Indicates that the steering column has not been locked.</p>

TRIP COMPUTER

Operating fault messages

Examples of messages	Interpretation of messages
« WARNING: Check Lighting »	Indicates a fault in the headlights.
« Check vehicle »	Indicates a fault in one of the pedal sensors, battery management system or oil level sensor.
« WARNING: Check Airbag »	Indicates a fault in the additional restraint system of the seat belts. In the event of an accident, it is possible that they may not be triggered.
Check Anti- Pollution System	Indicates a fault in the vehicle's particle filter system.

These appear with the  warning light and mean that you should drive very carefully to an approved dealer as soon as possible. If you fail to follow this recommendation, you risk damaging your vehicle.

They disappear when the display selection key is pressed or after several seconds and are stored in the computer log. The

 warning light stays on. Examples of operating fault messages are given in the following pages.

TRIP COMPUTER

1

Warning messages

Examples of messages	Interpreting the display selected
« WARNING: Engine Failure Risk »	Indicates an injection fault, the vehicle's engine has overheated or there is a serious engine fault.
« WARNING: Steering Fault »	Indicates a fault in the steering system.
" WARNING: Braking System " or " WARNING: STOP Vehicle "	Indicates a fault in the braking system. Apply the electronic parking brake manually and ensure that the vehicle is immobilised using a chock.
« WARNING: Electric System »	Indicates a fault in the vehicle battery charging circuit (alternator etc.).
Puncture	Indicates a puncture on the tyre displayed on the instrument panel.

These appear with the **STOP** warning light and require you to stop immediately, for your own safety, as soon as traffic conditions allow. Stop your engine and do not restart it. Call an approved Dealer.

Some examples of warning messages are given below. **Note:** the messages appear on the display either individually or alternately (when there are several messages to be displayed), and may be accompanied by a warning light and/or a beep.

TRIP COMPUTER

Displays and indicators



Instrument panel

It illuminates when the vehicle is unlocked.

Rev counter 1

(scale x 1,000)

Low engine oil level warning

When the engine is started, the display **2** alerts the driver if the oil level is at its minimum. Refer to the information on the "Engine oil level" in Section 4.

Trip computer 2

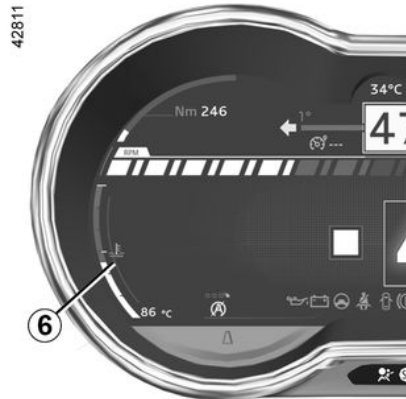

Refer to the information on the "Trip computer" in Section 1.

Coolant temperature indicator

Warning light **5** ("Normal " mode) or warning light **6** ("Sport" or "Track " mode) lights up in red when the ignition is switched on or when the engine is started, then switches off after a few seconds.

Depending on which driving mode is selected, when warning light **3** ("Normal " mode) or warning light **6** ("Sport" or "Track" mode) is displayed in blue, this indicates that the coolant temperature is low. The engine

performance is limited (power, torque and engine speed).

When the warning light **3** disappears or the warning light **6** appears in white, this indicates that the engine performance is optimal.

When warning light **5** or **6** is displayed in red, this indicates overheating. Stop the vehicle. Allow the engine to cool before checking the coolant level (please refer to "Coolant levels" in Section 4). If the level is normal, the warning light is related to something else. Call an approved Dealer.

Note: the red zone **4** indicates the maximum engine speed limit (in rpm). It changes according to the coolant temperature.

TRIP COMPUTER

1 Exterior temperature indicator 7



Clock 8

Fuel gauge 9

Speedometers 10 and 11



(km or miles per hour)

The indicator **10** is provided for information.

Control your speed according to the approved speedometer only **11**.

Excessive speed audible alarm

Depending on the vehicle, a beep sounds when the vehicle is travelling at over 74 mph (120 km/h).

Indicators in "Sport" or "Track" mode

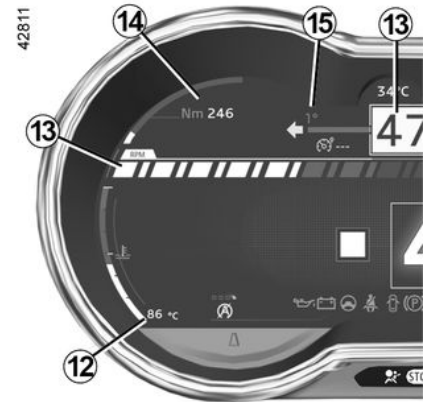

Depending on the driving mode selected (refer to "Choice of driving mode" in Section 2), the following information may be displayed:

– the engine coolant temperature **12**. Indicates the temperature (in degrees Celsius or Fahrenheit) of the coolant.

Note: the clutch operating temperature must be below approximately 115°C. If the temperature is higher, a message appears on the instrument panel;

TRIP COMPUTER



42813

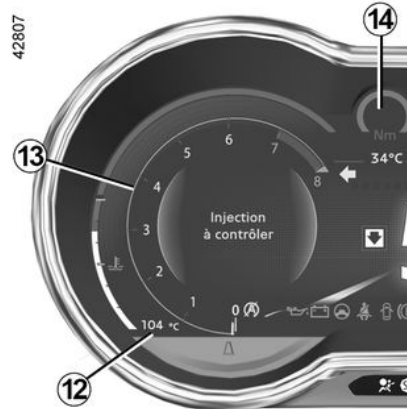

42807



42710

- the engine speed **13**. Indicates the engine rotation speed (in rpm);
- the engine torque **14**. Shows the available torque level (in Newton metres);
- the steering wheel angle **15** (in degrees);
- the engine power **16**. Shows the engine power in real time (in DIN horsepower);
- estimated range with remaining fuel **17**.



42809

Instrument panel in miles

(depending on vehicle, option to switch to km/h)

- With the vehicle stationary, press several times on button **19** or **20** until the settings menu is displayed. Press and hold button **18**, **19** or **20** to enter the menu;
- using button **19** or **20**, select "Unit";
- briefly press button **18** to change the unit. The new unit is immediately applied.

TRIP COMPUTER

1



To return to the previous mode, repeat the same operation.

Note: once the battery is switched off, the trip computer automatically returns to the original unit of measurement.

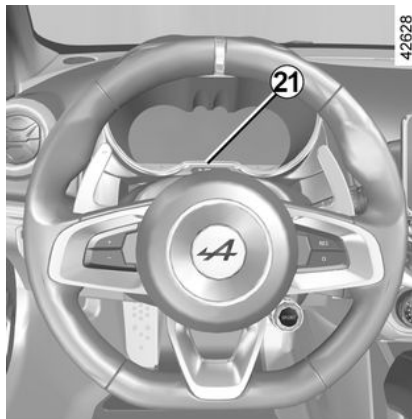

i No objects must be placed on the instrument panel support **21**.
Risk of damage to the instrument panel display.

Vehicle settings personalisation menu

42799



On equipped vehicles, this function, which is integrated into the trip computer **1**, allows you to activate/deactivate and adjust some of the vehicle's functions.

Accessing the vehicle settings customisation menu

With the vehicle stationary, press several times on button **3** or **4** until the settings menu is displayed. Press and hold button **2** to enter the menu.

TRIP COMPUTER

Adjusting the settings

42710



Use button **2** to browse and select the function to modify.

Depending on the vehicle, the following functions are available:

- automatic locking of the doors while driving;
- activation of the rear Park Assist function;
- activation of the front Park Assist function;
- automatic activation of night mode;
- clock;

42635



- selecting a language;
- choice of units: km/h or mph.



The settings personalisation menu cannot be used when driving. Over 2 mph (4 km/h), the on-board display automatically switches back to trip computer mode and the "Settings menu: when stationary" message appears to warn you.

42710



function activated



function deactivated

Once a line has been selected, keep pressing either button **2** or **3** to modify the function.

TRIP COMPUTER

1



For "Units" or "Language", you have to make a further selection. In this case, make your selection using button **3** or **4** and confirm by holding button **2**.

To exit the menu, select "Exit" using button **3** then confirm by briefly pressing button **2**.

Multifunction screen

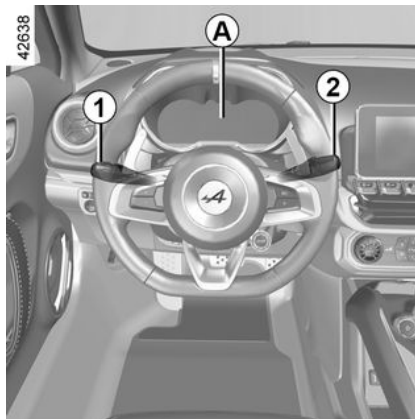

This function is an additional aid. It cannot, therefore, under any circumstances replace the vigilance or the responsibility of the driver. The driver must always pay attention to the rules of the road.

Display A



This system provides information on some technical parameters constantly and in real time.

After the vehicle ignition is switched on, scroll upwards or downwards (using button **4** or **5** on the stalk **2**) until the multifunction screen menu is displayed on screen **A**.

TRIP COMPUTER



Depending on the vehicle, you can press button **3** on the stalk **1** to display the following:

- opening of the throttle valve;
- pressure in the braking circuit;
- turbocharging pressure in real time;
- measurement of transverse and longitudinal acceleration.



Opening of the throttle valve **6**

Provides information on the position of the throttle valve flap (in percent).

Pressure in the braking circuit **7**

Shows the pressure (in bar) in the braking circuit. The higher the pressure, the more powerful the braking will be.

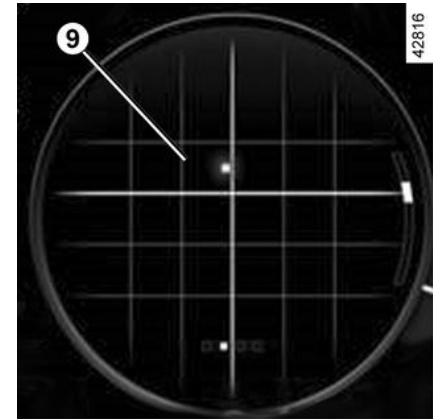

Turbocharging pressure in real time **8**

Provides information on the use of the turbocharger in real time and on the available turbocharging reserve (in millibar).

Measurement of transverse and longitudinal acceleration **9**

When you accelerate, slow down or turn, the vehicle undergoes transverse and longitudinal acceleration.

This screen allows you to see these and measure them in real time.

TRIP COMPUTER

1 Clock and outdoor temperature

Clock

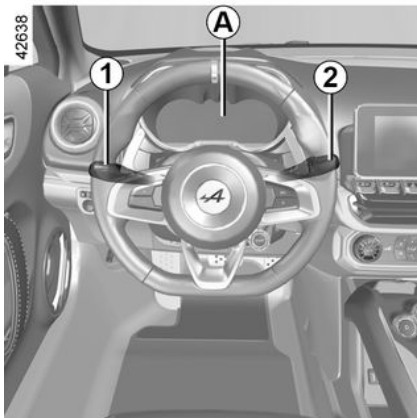

To access the time setting for the display **A**, with the vehicle stationary, press several times on button **4** or **5** until you reach the settings menu. Press and hold button **3**, **4** or **5**.



Press button **5** on the stalk **2** until the clock is displayed.

- Briefly press button **3** on the stalk **1** to access the hour setting;
- briefly press button **4** or **5** repeatedly to set the hour;
- briefly press button **3** to access the minute setting;
- briefly press button **4** or **5** to set the minutes;
- briefly press button **3** to confirm.

To exit the clock menu, briefly press button **3** again.



If the power supply is cut (battery disconnected, supply wire cut, etc.), the clock must be reset.

We recommend that you do not adjust these settings while driving.

Exterior temperature indicator

Special feature:

When the exterior temperature is between $-3\text{ }^{\circ}\text{C}$ and $+3\text{ }^{\circ}\text{C}$, the $^{\circ}\text{C}$

TRIP COMPUTER

characters flash (signalling a risk of ice on the road).



Exterior temperature indicator

As ice formation is related to climatic exposure, local air humidity and temperature, the external temperature alone is not sufficient to detect ice.

WARNING LIGHTS

1 The display of information shown below **DEPENDS ON THE VEHICLE EQUIPMENT AND COUNTRY.**



Instrument panel A: this lights up when the vehicle is unlocked. Brightness can be adjusted from the vehicle customisation menu (please refer to "Vehicle settings customisation menu" in Section 1).

In some cases, the appearance of a warning light is accompanied by a message.

 **Side light tell-tale light**

 **Main beam headlight tell-tale light**

 **Dipped beam headlight tell-tale light**

 **Rear fog lights tell-tale**

 **Left-hand direction indicator tell-tale light**

 **Right-hand direction indicator tell-tale light**

 For your own safety, the **STOP** warning light requires you to stop immediately, as soon as traffic conditions allow. Switch off the engine and do not restart it. Call an approved Dealer.

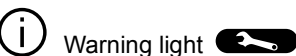
 Warning light means you should drive **very carefully to an authorised dealer as soon as possible.** If you fail to follow this recommendation, you risk damaging your vehicle.



If no lights or sounds are apparent, this indicates a fault in the instrument panel. This indicates that it is essential to stop immediately (as soon as traffic conditions allow). Ensure that the vehicle is correctly immobilised and contact an approved Dealer.

The display of information shown below **DEPENDS ON THE VEHICLE EQUIPMENT AND COUNTRY.**

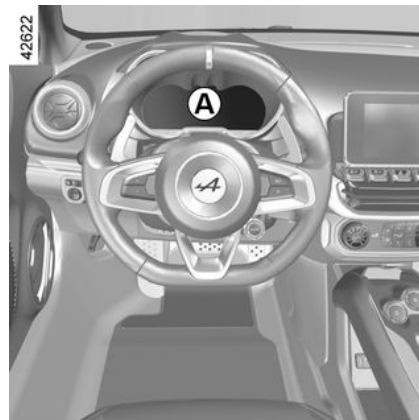

STOP Urgent stop warning light

WARNING LIGHTS

This lights up when the ignition is switched on and goes out as soon as the engine is started. It may appear with other warning lights and/or messages and may be accompanied by a beep.

For your own safety, it requires you to stop immediately, as soon as traffic conditions allow. Switch off the engine and do not restart it.

Call an approved Dealer.

Brake circuit fault detection warning light

This lights up when the ignition is switched on and goes out after a few seconds.

If it comes on during braking and is

accompanied by the **STOP** warning light and a beep, it indicates that the fluid level in the circuit is low or that there is a braking system fault.

Stop as soon as traffic conditions allow and consult an approved dealer.

Battery charge warning light

This lights up when the ignition is switched on and goes out after a few seconds.

If it comes on on the road,

accompanied by the **STOP** warning light and a beep, this indicates an overload or discharge in the electrical circuit.

Stop as soon as traffic conditions allow and consult an approved dealer.

Oil pressure warning light

This lights up when the ignition is switched on and goes out after a few seconds.

If it comes on on the road,

accompanied by the **STOP** warning light and a beep, stop immediately and cut the ignition.

Check the oil level. If the level is normal, the warning light is related to something else.

Call an approved Dealer.

Variable power assisted steering warning light

It lights up when the ignition or the engine is switched on and goes off after a few seconds.

If it comes on while driving, alongside

the warning light **STOP**, this means there is a system fault.

Stop as soon as traffic conditions allow and consult an approved dealer.

The display of information shown below DEPENDS ON THE VEHICLE EQUIPMENT AND COUNTRY.

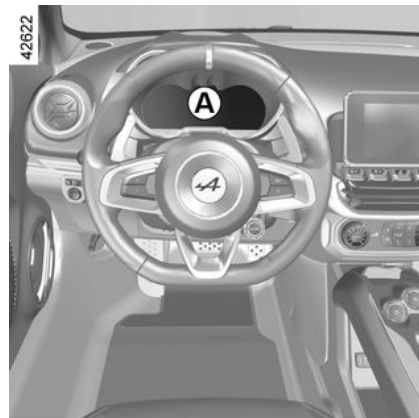

Warning light

This lights up when the ignition is switched on and goes out as soon as the engine is started. It can light up in conjunction with other warning lights and/or messages on the instrument panel.

It means you should **drive very carefully** to an approved Dealer as soon as possible. If you fail to follow this recommendation, you risk damaging your vehicle.

WARNING LIGHTS

1



Toxic fume filter system warning light

On vehicles which are equipped with it, this light comes on when the engine is started and, depending on the vehicle, when the ignition is switched off if the engine is on standby (refer to the information on the "Stop and Start function" in Section 2), then it goes out.

- If it lights up continuously, contact an approved dealer as soon as possible;
- If it flashes, reduce the engine speed until the light stops flashing. Contact your approved Dealer as soon as possible;

Refer to the information on "Maintenance and emission control advice" in Section 2.



Handbrake or electronic parking brake warning light

Refer to the information on the "Electronic parking brake" in Section 2.



Coolant temperature warning light

The location of the warning light on the instrument panel depends on the choice of driving mode selected and the coolant temperature (refer to "Displays and indicators" in Section 1).

It lights up in red when the ignition is switched on or when the engine is started, then after a few seconds illuminates in blue, white or switches off depending on the engine coolant temperature level.

If it appears in red, stop and leave the engine idle for a minute or two. The temperature should lower and the warning light should appear in white or switch off. If not, stop the engine. Allow it to cool before checking the coolant level (please refer to "Coolant levels" in Section 4). If the level is normal, the warning light is related to something else. Call an approved Dealer.

The display of information shown below DEPENDS ON THE VEHICLE EQUIPMENT AND COUNTRY.

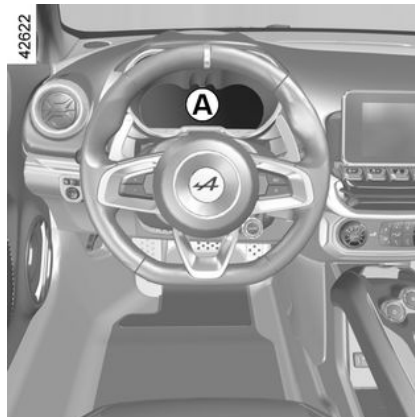

Anti-lock braking warning light

This lights up when the ignition is switched on and goes out after a few seconds.

If it comes on when you are driving, it indicates a fault on the antilock braking system.

Braking will then be as normal, without the ABS. Contact your approved Dealer straight away.



Gear change indicators

In manual mode, they illuminate to advise you to change to a higher gear (up arrow) or lower gear (down arrow).

WARNING LIGHTS

Refer to the information on "Driving advice, ECO-driving" in Section 2.



Warning light for the electronic stability control (ESC) and traction control system

This lights up when the ignition is switched on and goes out after a few seconds.

There are several reasons for the warning light coming on: refer to the information on "Driver correction devices and aids" in Section 2.



Electronic stability control (ESC) and traction control system deactivation warning light

Refer to "Choice of driving mode" and "Driving correction devices and aids" in Section 2.



Speed limiter warning light

Refer to the information on the "Speed limiter" in Section 2.



Cruise control warning light

Refer to the information on "Cruise control" in Section 2.



Engine standby warning light

Refer to the information on the "Stop and Start function" in Section 2.



Unavailability of engine standby warning light

Refer to the information on the "Stop and Start function" in Section 2.



Tyre under-inflation warning light

This lights up when the ignition is switched on or when the engine starts, then disappears after a few seconds.

Note: refer to the information on the "Tyre pressure monitoring system" in Section 2.

The display of information shown below DEPENDS ON THE VEHICLE EQUIPMENT AND COUNTRY.



Warning light for the Airbag

This lights up when the ignition is switched on and goes out after a few seconds.

If it does not light up when the ignition is switched on, or if it lights up when the engine is running, this indicates a fault in the system.

Contact your approved Dealer as soon as possible;



Low fuel level warning light

This lights up when the ignition is switched on and goes out after a few seconds.

If it lights up when driving, fill up with fuel as soon as possible. There is only approximately 31 miles (50 km) worth of fuel left. Refer to the information on "Special features of petrol versions" in Section 2.



Opening element(s) open warning light

It illuminates and may be accompanied by a message on the instrument panel to inform you that one of the opening elements is open.



Seat belt reminder warning light

Refer to the information on "Seat belts" in Section 1.



Particle filter system warning light (petrol version)

Refer to the information on "Special features of petrol versions" in Section 2.

WARNING LIGHTS

1

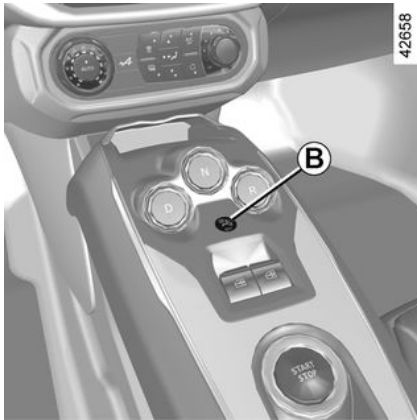

On the centre console **B**



Airbag passenger OFF

Refer to the information on "Child Safety: deactivation/activation of the front passenger airbag" in Section 1.

STEERING

Steering wheel

Adjusting the steering wheel height and depth

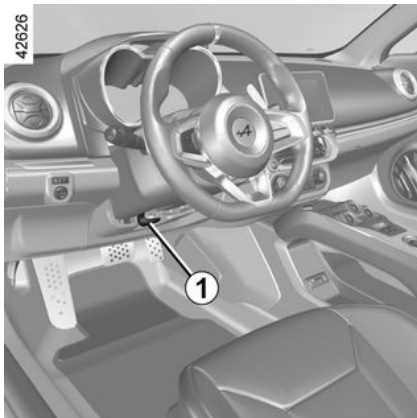

Pull the lever **1** and set the steering wheel to the required position, then push the lever beyond the point of resistance to lock the steering wheel in place.

Make sure that the steering wheel is correctly locked.

Power-assisted steering

Variable power assisted steering

The variable power-assisted steering system is equipped with an electronic

control system which alters the level of assistance to suit the vehicle speed.

Steering is made easier during parking manoeuvres (for added comfort) while the force needed to steer increases progressively as the speed rises (for enhanced safety at high speeds).

Note: the power-assisted steering depends on the driving mode selected.

(Refer to "Choice of driving mode" in Section 2)



For safety reasons, only adjust the steering wheel when the vehicle is stationary.



Never leave the steering wheel on full lock when the vehicle is stationary.



With the engine switched off, or if there is a system fault, it is still possible to turn the steering wheel. The force required will be greater.



Never switch off the ignition when travelling downhill, and avoid doing so in normal driving (power steering and brake servo will not function).

REAR VIEW

1

Rear view mirrors

Exterior rear view mirrors

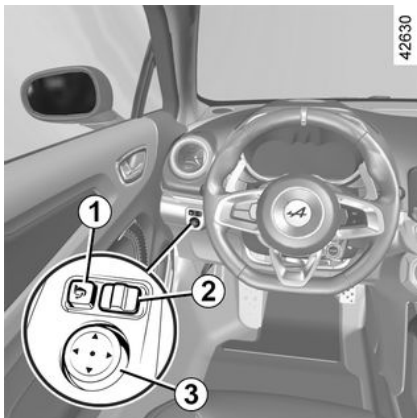

Adjustment

Select the door mirror using switch **2**, then use the control **3** to adjust it to the desired position.

Heated rear view mirrors

Please refer to the information on "Manual air conditioning" and "Automatic climate control" in Section 3.

Folding rear view mirrors

Press the switch **1** to fold in the door mirrors. Press the switch **1** again to fold out the door mirrors.

Welcome and goodbye function

(depending on the vehicle)

When the door mirrors are not folded in by pressing the switch **1**, they:

- fold in automatically when the vehicle is locked;
- fold out automatically when the vehicle is unlocked.



Objects observed in the rear view mirror glass are actually closer than they appear.

For your safety, take this into account in order to correctly assess the distance before any manoeuvre.



For safety reasons, carry out any adjustments while the vehicle is stationary.

Interior rear view mirror

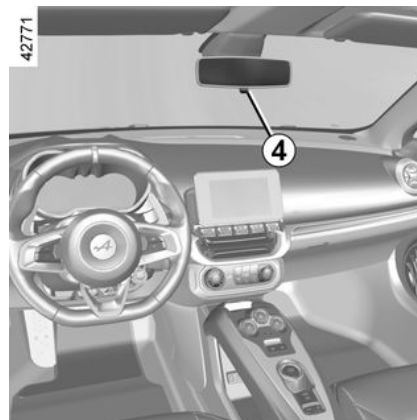

Its position can be adjusted.

Rear view mirror with lever **4**

When driving at night, to avoid being dazzled by the headlights of the vehicle behind, shift the small lever **4** located behind the rear view mirror.

Rear view mirror without lever **4**

The rear view mirror darkens automatically at night if you are being followed by a vehicle with its lights on.

LIGHTING AND SIGNALS

Exterior lighting and signals



Side lights

 Turn the ring **2** on the stalk **1** until the symbol appears opposite the mark **3**. This indicator light on the instrument panel comes on.

Daytime running lights function

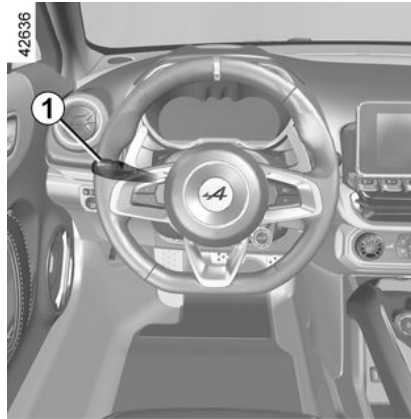

Rotate the ring **2** on the stalk **1** until the AUTO symbol is aligned with the mark **3**.

Note: in the AUTO position, the daytime running lights come on automatically when the engine is started and switch off when the engine is stopped.



Before driving at night, check that the electrical equipment is operating correctly and adjust the headlight beams (if your vehicle is not carrying its normal load). As a general precaution, check that the lights are not obscured (by dirt, mud, snow or objects being transported).

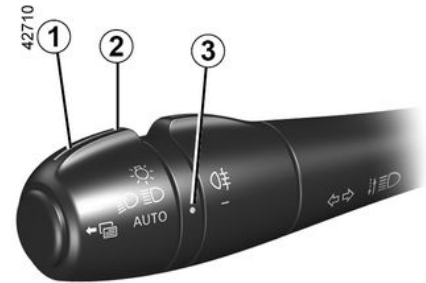

Dipped beam headlights



Manual operation

LIGHTING AND SIGNALS

1

Turn the ring **2** until the symbol is opposite the mark **3**. This indicator light on the instrument panel comes on.

Automatic operation

Turn the ring **2** until the AUTO symbol is opposite the mark **3**: with the engine on, the dipped beam headlights switch on or off automatically according to the exterior light level, without any action on the stalk **1**.

Main beam headlights

 With the engine running and the dipped beam headlights lit, push stalk **1**. This indicator light on the instrument panel comes on.

To return to the dipped headlight position, pull the stalk **1** towards you again.

Switching off the lights

Rotate the ring **2** until the AUTO symbol is aligned with the mark **3**. If the main beam headlights are not illuminated, the lights switch off once the engine stops, the driver's door is opened or the vehicle is locked.

Lights-on reminder audible alarm

A warning beep sounds when the driver's door is opened to warn you that the lights are still on.

Welcome and goodbye function

(depending on the vehicle)

Once the function is activated, the side lights come on automatically when the Renault card is detected or when the vehicle is unlocked.

They switch off automatically:

- approximately one minute after lighting up;
 - when starting the engine, based on the position of the lighting stalk;
- or
- upon locking the vehicle.

42710



Rear fog lights

 Turn centre ring **4** on the stalk until the symbol faces mark **3**, then release it.

Operation of the fog lights depends on the exterior lighting selected, and an indicator light will light up on the instrument panel.

Do not forget to switch off the fog lights when they are no longer needed, to avoid inconveniencing other road users.

Switching off the lights

Rotate the ring **4** again to align the mark **3** with the symbol corresponding

LIGHTING AND SIGNALS

to the rear fog lights. The warning light on the instrument panel goes out.

The rear fog lights switch off when the exterior lights are switched off.



When driving in fog or snow, or when transporting objects which are higher than the roof, the headlights do not come on automatically.

The fog lights are controlled by the driver: the indicator light on the instrument panel informs you whether they are on (indicator light on) or off (indicator light off).

AUDIBLE AND VISUAL SIGNALS

1

Horn

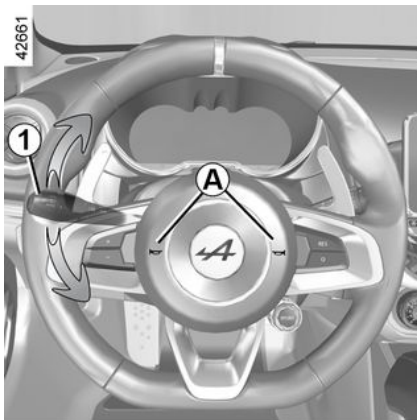

Press the steering wheel boss **A** to sound the horn.

Headlight flasher

To flash the headlights pull the stalk **1** towards you.

Direction indicators

Move stalk **1** parallel to the steering wheel and in the direction you are going to turn it.

One-touch mode

Briefly shift the stalk **1** upwards or downwards, not exceeding the point of resistance, then release it: the stalk

will return to its original position and the direction indicator light concerned will flash three times.

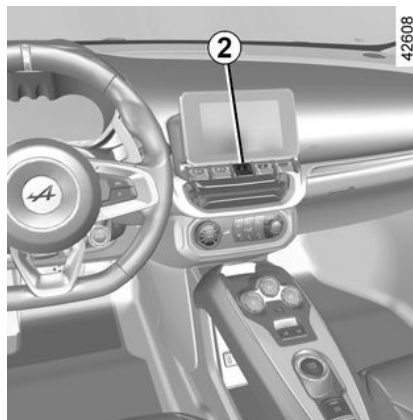

deceleration. You can switch them off by pressing the switch **2** once.

Hazard warning lights



Press the switch **2**.

This switch activates all four direction indicators and the side indicator lights simultaneously. It must only be used in an emergency to warn drivers of other vehicles that you have had to stop in an area where stopping is prohibited or unexpected, or that you are obliged to drive under special conditions.

Depending on the vehicle, the hazard warning lights may come on automatically under heavy

WIPER

Windscreen washer, wiper

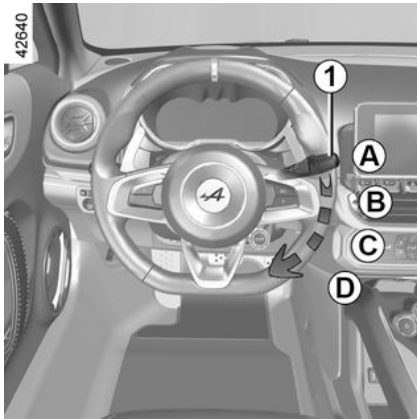

With the ignition on, move the stalk **1**.

A. stopping

B intermittent wiping

2. The wipers will pause for several seconds between sweeps. It is possible to change the time between sweeps by turning ring .

C. slow continuous wiping

D. fast continuous wiping

 Positions **B**, **C** and **D** are accessible with the ignition on.

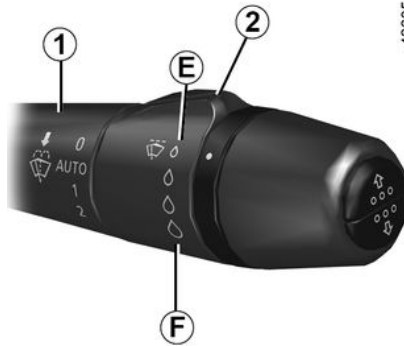

Special feature

When driving, the wiping speed slows down whenever the vehicle stops. For example, fast wiping speed will slow to normal wiping speed.

As soon as the vehicle moves off, wiping will return to the speed originally selected. Any action on the stalk **1** is given priority and cancels automatic operation.

 When working in the engine compartment, ensure that the windscreen wiper stalk is in position **A** (off).
Risk of injury.

Vehicles with automatic wiper function

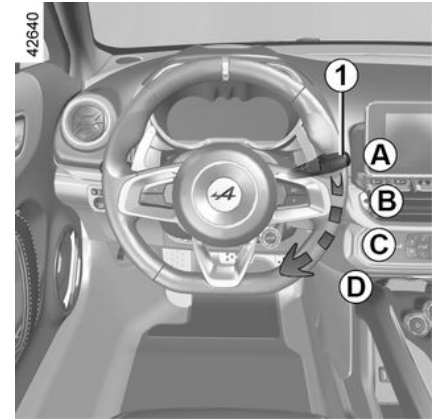

With the engine running, move the stalk **1**.

A off

WIPER

1

i Position **C** is accessible with the ignition on.
Positions **B** and **D** are accessible only with the engine running.



B automatic wiper function

When this position is selected, the system detects water on the windscreen and triggers the wipers at a suitable wiping speed. It is possible to change the triggering threshold and the interval between sweeps by turning the ring **2**:

- **E**: minimum sensitivity
- **F**: maximum sensitivity

Note: in foggy weather or during snowfalls, wiping is not automatically triggered and the function remains under the driver's control.

C. slow continuous wiping

D fast continuous wiping

Note:

- the rain sensor is only intended as a driving aid. In the event of reduced visibility, the driver should manually activate the wipers. In foggy weather or during snowfalls, wiping is not automatically triggered and remains under the driver's control;
- in the event of temperatures below zero, automatic wiping is not activated when the vehicle is started. It is automatically activated as soon as the vehicle exceeds a certain speed (approximately 5 mph (8 km/h));
- do not activate automatic wiping in dry weather;
- fully de-ice the windscreen before activating automatic wiping;
- when washing using a roller type car wash, return the stalk **1** to the off position **A** to deactivate automatic wiping.

Windscreen washer



With the ignition on, pull the stalk **1** towards you.

A brief pull will trigger a single sweep of the wipers, in addition to the windscreen washer.

A longer pull will trigger three sweeps of the wipers followed, a few seconds later, by a fourth, in addition to the windscreen washer.

WIPER

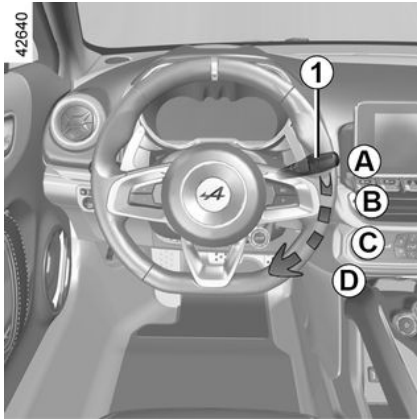

Before taking any action on the windscreen (washing the vehicle, de-icing, cleaning the windscreen, etc.) return the stalk **1** to position **A** (off).

Risk of injury and/or damage.



Efficiency of a wiper blade

Check the condition of the wiper blades. How long they last depends on you:

- it must remain clean: clean the blade and the screen regularly with soapy water;
- do not use it when the screen is dry;
- free it from the screen when it has not been used for a long time.

In any event, replace them as soon as their performance is reduced: approximately every year (refer to the information on "Wiper blades: replacement" in Section 5).

Precautions for using the wipers

- In freezing or snowy weather, clear the screen before starting the wipers (risk of motor overheating);
- ensure that no objects are obstructing the travel of the blade.

FUEL TANK

1

Fuel grade



Use a high-grade fuel that complies with the legislation in force in each country. It must comply with the specifications shown on the label on the cover **1**. Refer to the information on "Engine specifications" in Section 6.



After filling, check that the cover is closed.



Never press the valve **2** using your fingers. Do not wash the filler area with a high pressure washer.



Do not mix even small amounts of petrol (unleaded or E85) with diesel.

Do not use ethanol-based fuel if your vehicle is not compatible with this fuel.

Do not add additive to the fuel (additive, reagent, etc.), you could damage the engine. If you wish to add an additive to the fuel, use a product approved by our Technical Department. Consult an approved dealer.

It is **essential** to use unleaded petrol. The octane rating (RON) must comply with the information shown on the label on the cover **1**. Refer to the information on "Engine specifications" in Section 6.



Fuel types that conform to European standards with which the engines of vehicles sold in Europe are compatible: refer to the "Engine specifications" table in Section 6.



No modifications whatsoever are permitted on any part of the fuel supply system (electronic units, wiring, fuel circuit, injectors, protective covers, etc.) as this may be dangerous (unless undertaken by qualified Network personnel).

Filling with fuel

With the ignition off, insert the nozzle to open the valve **2** and insert it **fully** before pressing the trigger to fill the tank (to prevent the risk of splashing).

Keep the nozzle in this position throughout the entire filling operation.

When the pump cuts out automatically at the end of the filling procedure, a maximum of two further filling attempts may be made, as there must be

FUEL TANK

sufficient space in the fuel tank to allow for expansion.

Make sure that no water enters the fuel tank during filling. The valve **2** and its surround must remain clean.

Using leaded petrol will damage the antipollution system and may lead to a loss of warranty.

To ensure that the fuel tank is not filled with leaded petrol, the fuel tank filler neck consists of a restrictor fitted with a safety system which **only allows a nozzle for unleaded petrol to be used** (at the pump).



Persistent smell of fuel

If you notice a persistent fuel odour you should:

- stop the vehicle when traffic conditions allow it and switch off the ignition;
- switch on the hazard warning lights and ask your passengers to leave the vehicle and stay clear of the traffic;
- contact an authorised dealer.



The engine must be switched off for refuelling (and not just on standby for vehicles equipped with the Stop and Start function): you must switch off the engine completely (please refer to the information on "Starting and stopping the engine" in Section 2).

Fire hazard.

RUNNING IN

Running-in the engine

Up to **620 miles (1,000 km)**, do not exceed 80 mph (130 km/h) in top gear or 3,500 rpm in the other gears and do not accelerate by fully pressing the accelerator pedal.

Avoid "sporty" driving until the vehicle mileage reaches approximately **1,864 miles (3,000 km)**.

You should only expect top performance from your vehicle after this period.

Note: for a new vehicle in the running-in phase, the coolant level may be higher than the "MAXI" mark on the tank, then drop to between the "MINI" and "MAXI" marks. This does not present a risk.

Service intervals: refer to your vehicle's maintenance document.



It is forbidden to launch a standing start procedure during the running in period of your vehicle (risk of engine deterioration).

For more information on the starting procedure, please refer to the information on the "Standing start procedure" in Section 2.

Running-in the brake pads

If the vehicle is equipped with new pads, the brakes require running-in.

Therefore, it is recommended that you do not press the brake pedal too hard until the vehicle mileage reaches approximately 124 miles (200 km).

For more information on the operations required for running in, please consult an approved dealer.

STARTING, STOPPING THE ENGINE

Starting with "hands-free" card



The card must be in the detection zone **1**.

With the gearbox in P or N position (refer to "Automatic gearbox" in Section 2) and your foot on the brake pedal, press the button **2** to start the engine.

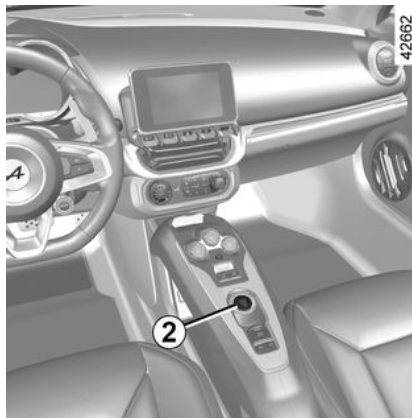

"Hands-free" starting with the luggage compartment open

In this case, the card should not be located in the luggage compartment, to prevent the risk of loss.



Driver's responsibility when parking or stopping the vehicle

Never leave an animal, child or adult who is not self-sufficient alone in your vehicle, even for a short time. They may pose a risk to themselves or to others by starting the engine, activating equipment such as the electric windows or locking the doors. Also, in hot and/or sunny weather, please remember that the temperature inside the passenger compartment increases very quickly.

RISK OF DEATH OR SERIOUS INJURY.

STARTING, STOPPING THE ENGINE

Starting the vehicle using the remote control card

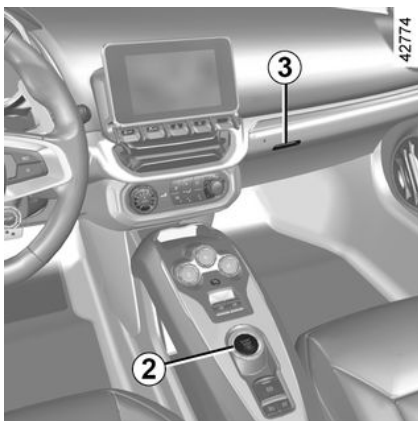

When you get into the vehicle, insert the card's built-in key, pointing towards you, fully into the card reader **3**.

With the gearbox in P or N position (refer to "Automatic gearbox" in Section 2) and your foot on the brake pedal, press the button **2** to start the engine.

Special features

– If one of the conditions required for starting is not met, the "Press brake + start" or "Select P" message is displayed on the instrument panel;

– in some cases, it will be necessary to move the steering wheel whilst pressing the start button **2** to help unlock the steering column: in this case the "Turn Steering Wheel + START" message will warn you.

Accessories function

(switching on the ignition)

Once you have gained access to your vehicle, you may use some of its functions (radio, navigation, wipers, etc.).

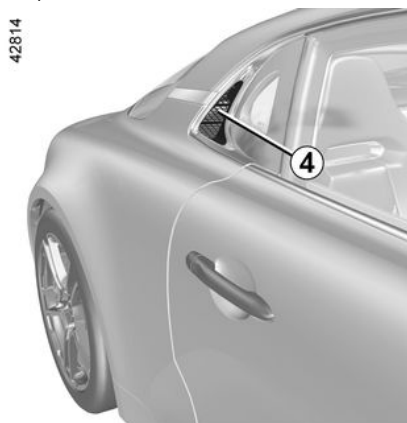

For other functions:

– **vehicles equipped with a "hands-free" card**: with the card in the passenger compartment, press the button **2** without pressing the pedals;

– **vehicles equipped with a remote control card**: insert the card into the reader **3**.



Before starting, ensure that nothing will obstruct the air vents **4**.

Operating faults

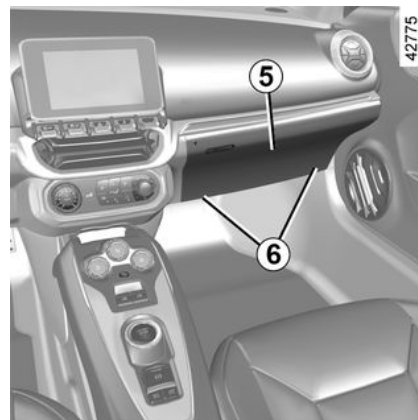

In certain cases, the hands-free card may not work:

– when the card battery is drained, flat battery, etc.
– near to appliances operating on the same frequency as the card (monitor,

STARTING, STOPPING THE ENGINE

mobile phone, video game device, etc.);

– the vehicle is located in a high electromagnetic radiation zone.

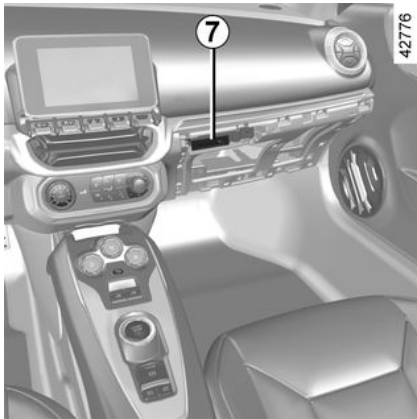

The "Insert keycard" message appears on the instrument panel.

Pull the cover **5** by the flaps **6** to unclip it.

Insert the card fully into the card reader **7**.

Conditions for stopping the engine

The vehicle must be stationary and the gearbox in position P or N (refer to "Automatic gearbox" in Section 2).

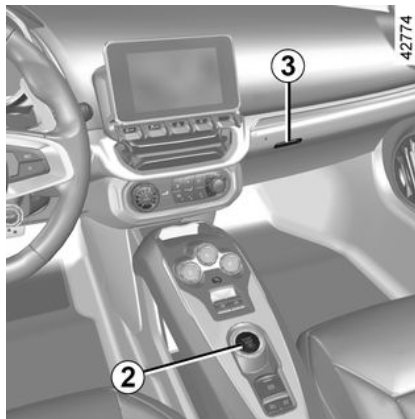

Special feature

Depending on the vehicle, accessories (e.g. radio) stop working either when the engine is switched off or when the driver's door is opened or when the doors are locked.



Never switch off the ignition before the vehicle has stopped completely. Once the engine has stopped, the brake servo, power-assisted steering, etc., and the passive safety devices such as the airbags and pretensioners will no longer operate.

"Hands-free" card

With the card in the vehicle, press the button **2**: the engine is switched off. The steering column is locked when the driver's door is opened or the vehicle is locked.



When you leave your vehicle, especially if you have your card with you, check that the engine is completely switched off.

STARTING, STOPPING THE ENGINE

2



Driver's responsibility when parking or stopping the vehicle

Never leave an animal, child or adult who is not self-sufficient alone in your vehicle, even for a short time. They may pose a risk to themselves or to others by starting the engine, activating equipment such as the electric windows or locking the doors. Also, in hot and/or sunny weather, please remember that the temperature inside the passenger compartment increases very quickly.

RISK OF DEATH OR SERIOUS INJURY.

Remote control card

With the card in the reader **3**, press the button **2**: the engine stops. Removing the card from the reader locks the steering column.

Special feature

If the card is no longer in the passenger compartment or if the card's battery is flat, when the vehicle is stationary and you try to switch the

engine off, the "Keycard absent : press/hold START" message appears on the instrument panel: press the button **2** for at least three seconds.

Stop and Start function

This system enables a reduced fuel consumption and lower greenhouse gas emissions.

The system is activated automatically when the vehicle is started. While driving, the system stops the engine (standby) when the vehicle is at a standstill (traffic jam, traffic lights, etc).

Conditions for engine standby

- The vehicle has been driven since its last stop;
- and
- the gearbox is in D, M or N position (refer to "Automatic gearbox" in Section 2);
- and
- the brake pedal is pressed (sufficiently hard);
- and
- and the accelerator pedal is not pressed;
- and
- the speed is zero for around 1 second.

The engine is kept on standby if P position (refer to the information on the "Automatic gearbox" in Section 2) is engaged or if N position is engaged and the parking brake is applied while the brake pedal is released.

The warning light  on the instrument panel is lit when the engine is on standby.

The vehicle equipment remains operational while the engine is stopped.



If the engine is put in standby, the electronic parking brake is not applied automatically.



Keep your vehicle stationary when the engine is on standby (shown by the warning

light  on the instrument panel).

STARTING, STOPPING THE ENGINE



Before leaving the vehicle, the engine must be stopped and not just on standby (please see the information on "Starting, stopping the engine" in Section 2).

Preventing the engine from standing by

In certain situations, such as negotiating a crossroads for instance, it is possible (with the system activated) to keep the engine on so as to be ready to move off quickly.

Keep the vehicle stationary without pressing too hard on the brake pedal.

Conditions for coming out of engine standby

– The brake pedal is released and D or M position is engaged;

or

– the brake pedal is released, N position is engaged and the parking brake is released;

or

– the brake pedal is pressed again, P position is engaged or N position is

engaged and the parking brake is applied;

or

– the R position is engaged;

or

– the accelerator pedal is depressed.

Special note: depending on the vehicle, if you switch off the ignition when the engine is on standby, the



warning light may be displayed for a few seconds on the instrument panel.



The engine must be switched off for refuelling (and not just on standby for vehicles equipped with the Stop and Start function): you must switch off the engine completely (please refer to the information on "Starting and stopping the engine" in Section 2).

Fire hazard.

Conditions preventing the standby of the engine

Certain conditions prevent the system from using the engine standby function, especially when:

- reverse gear is engaged;
- the driver's door is not closed;
- the driver's seat belt is not fastened;
- the outdoor temperature is too low or too high;
- the battery is not sufficiently charged;
- the difference between the vehicle interior temperature and the automatic climate control setpoint is too high;
- the Sport or Track driving mode is activated (please refer to "Choice of driving mode" in Section 2);
- the altitude is too high;
- the gradient is too steep;
- the "Clear View" function is activated (refer to "Automatic climate control" in Section 3);
- the engine temperature is too low;
- ...

Warning light  is displayed on the instrument panel. This notifies you that engine standby is not available.

STARTING, STOPPING THE ENGINE

2



Before carrying out any operation in the engine compartment, the ignition must be switched off (refer to the information on "Starting, stopping the engine" in Section 2)

Special cases

With the engine on standby (traffic jam, traffic lights, etc.), if the driver unfastens their seat belt, opens the driver's door or gets out of their seat, the ignition will be switched off.

The handbrake is applied automatically.

To restart and reactivate the Stop and Start system, start the engine (refer to the information on "Starting, stopping the engine" in Section 2).

Special feature of the automatic engine re-start

Under certain conditions, the engine can restart on its own in order to guarantee your safety and comfort.

This may occur when:

- the outdoor temperature is too low or too high;

- the "Clear View" function is activated (refer to "Automatic climate control" in Section 3);
- the battery is not sufficiently charged;
- the vehicle speed is above 3 mph (5 km/h) (downhill slope, etc.);
- the brake pedal is pressed repeatedly or there is a braking system requirement;
- ...

Deactivating, activating the function

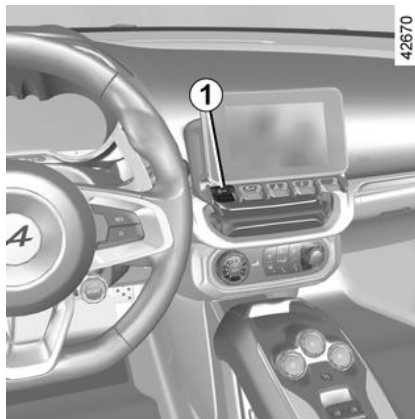

Press the switch **1** to deactivate the function. The "Stop & Start deactivated" message appears on the instrument panel and the switch **1** indicator light illuminates.

Pressing again will reactivate the system. The "Stop & Start activated" message appears on the instrument panel and the switch **1** indicator light goes out.



Special note: with the engine on standby, press switch **1** to automatically restart the engine.

The system reactivates automatically each time the vehicle is started using the start button (refer to "Starting, stopping the engine" in Section 2).

Operating faults

If the "Check Stop & Start" message appears on the instrument panel accompanied by the warning light **1**, this indicates that the system is deactivated.

Consult an approved dealer.

STARTING, STOPPING THE ENGINE



Before leaving the vehicle, the engine must be stopped and not just on standby (please see the information on "Starting, stopping the engine" in Section 2).

CHOICE OF DRIVING MODE

Driving mode activation control

2

Depending on the vehicle, three modes are available:

- Normal mode;
- Sport mode;
- Track mode.

i In Sport and Track modes, the Stop and Start function is disabled.

i For more information on the ESC system and traction control, refer to "Correction and driving aids" in Section 2.



i Depending on the selected mode, the ESC and traction control parameters, power-steering assistance rule, accelerator pedal and automatic gearbox can be modified.

Normal mode

It is the default operating mode, for the engine, gearbox, ESC system and traction control on each start-up.

If another mode is selected, press the switch **1** as many times as necessary to return to Normal mode. The instrument panel display is modified.

Sport mode

Press the switch **1** as many times as required to select Sport mode. The instrument panel display is modified and the "Sport" message is displayed on the instrument panel.

You can modify the operating settings for:

- the engine;
- the exhaust;
- the accelerator pedal;
- the power-assisted steering rule;
- the gearbox.

These modifications lower the activation threshold for the driving correction devices.

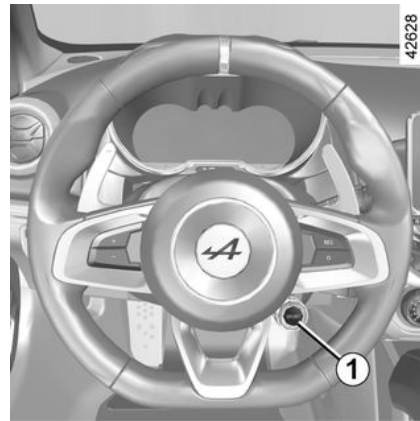

Track mode

CHOICE OF DRIVING MODE

(depending on the vehicle)

Track mode:

- delays operations on the ESC system and traction control;
- the gear changing times are reduced;
- the forced gearshift up is deactivated.

With the gearbox in D or M position (see the information on the "Automatic gearbox" in Section 2), press and hold the switch **1** to select Track mode. The instrument panel display is modified and the "Track" message is displayed on the instrument panel.

The "ESC Track" message is displayed on the instrument panel along with the



warning light to inform you that all of the ESC system and traction control functions have been modified.

The engine, exhaust, pedals and steering assistance rule adopt the same settings as in Sport mode.

The gearbox switches automatically to M position.

As the ESC system and traction control offer additional safety, it is not recommended to deactivate them.

Hazard warning lights switching on

Depending on the vehicle, these may light up in the event of sudden deceleration.

Note: in Sport and Track modes, the hazard warning light is deactivated in the event of a sudden deceleration.



In the event of high loads ("sporty" driving, etc.), the engine may protect itself by temporarily limiting its performance (speed and torque).

STANDING START PROCEDURE

2

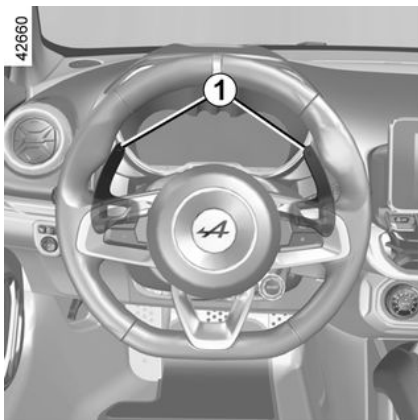

If fitted on the vehicle, with the vehicle stationary, the standing start procedure (Launch Control) is a function which permits maximum acceleration.

Note: the function must only be used when the mechanical components have reached their operating temperature.



Heavy use of the system will reduce the service life of the mechanical components (clutch, transmission, etc.).

The system is activated by:

- engine on, vehicle stationary;
- Sport or Track mode activated (refer to "Choice of driving mode" in Section 2);
- press the brake pedal using your left foot;
- keeping the brake pedal pressed, pull the two steering wheel paddles **1** until the "Launch Control ON" message appears on the instrument panel;
- release the paddles **1**;
- within 60 seconds, with your left foot still pressing the brake pedal, press the accelerator pedal fully **beyond the point of resistance** using your right foot (the engine speed will automatically stabilise at around 2,500 rpm, or approximately 3,000 rpm, depending on the vehicle, for a maximum of four seconds);
- within 4 seconds, release the brake pedal for a sporty vehicle start.



For an optimal standing start, use Sport mode.



Do not use this function on slippery or wet roads.
Risk of loss of control of the vehicle.

Conditions for non-activation of the system

Certain conditions will prevent activation of the system:

- the function is interrupted for approximately 10 minutes if five procedures have been carried out in a row or, depending on the vehicle, if a procedure has already been carried out within the preceding 15 seconds;
- engine coolant temperature too low;
- excessively high clutch temperature;
- gearbox oil temperature too high;
- excessive road gradient percentage;
- more than 1,000 or 1,500 starts depending on the vehicle (the function is then permanently deactivated);
- failure of a vehicle system (ESC...).

Note: if the function is inhibited by one of these conditions, the "Launch Control ON" message is not displayed on the instrument panel.

Activating the system

STANDING START PROCEDURE



It is forbidden to launch a standing start procedure during the running in period of your vehicle (risk of engine deterioration).

For more information on running in, please refer to the information on "Running in" in Section 2.



The function is programmed for a maximum number of 1,000 or 1,500 uses, depending on the vehicle. Beyond this limit, the function will be permanently deactivated.

To view the remaining number of uses, please contact an authorised dealer.

Note: the use of this function significantly accelerates tyre wear. Refer to "Tyres" in Section 5.



Because of the acceleration gained, this function should only be used if traffic conditions permit, and in compliance with the local driving regulations.

Please ensure all the conditions are met before each use.

Risk of accident or serious injury.

GEAR CONTROL

Automatic gearbox

2

Selection controls

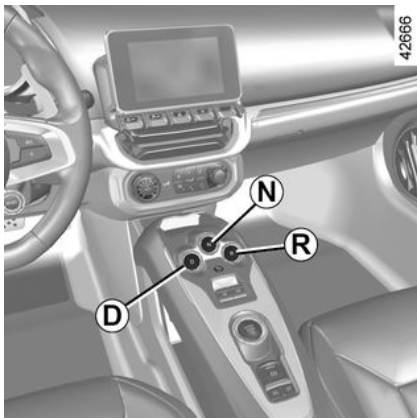

Switches R, N and D can be used to engage various gearbox positions:

- (R) **position**: reverse gear;
- (N) **position**: neutral;
- (P) **position**: park;
- (D) **position**: drive in automatic mode;
- (M) **position**: drive in manual mode.

The **5** symbol is shown on the instrument panel to indicate **which position is engaged and the indicator 4 indicates which gear is engaged.**

Gear change paddles 1 and 2

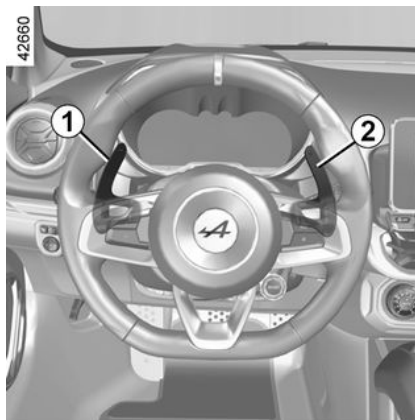

Paddles **1** and **2** can be used to change gear when the gearbox is in "manual mode" (M) or in "automatic mode" (D).

- 1.** Decrease switch for gear (-).
- 2.** Increase switch for gear (+).

Positions (P), (N) and (R) be engaged using the paddles.

Operation



With the vehicle stationary, when the ignition is switched on and the electronic parking brake is applied, the indicator lights built into the R, N and D switches will go out.

With the gearbox in position (P) or (N), keep your foot on the brake pedal (warning light **3** disappears from the instrument panel) and start the engine.

To disengage the "Park" position (P)

With the vehicle stationary and the engine running, press the brake pedal and select the desired position (R), (N), (M) or (D).

GEAR CONTROL

Position (R), (N), (D) or (M) must only be engaged while the vehicle is stationary, with your foot on the brake pedal, the accelerator pedal released and the engine running.

If the brake pedal is not fully pressed, the warning light **3** is displayed on the instrument panel.

Note:

- If the driver opens their door to exit the vehicle while (P) position is not engaged, a beep sounds and the "P not engaged" message is displayed on the instrument panel.
- The warning light **3** appears each time it is necessary to press the brake pedal in order to change the automatic gearbox position.

To engage the "Park" position (P)



With the vehicle stationary, the engine running or the ignition on, **press and hold switch N** until the indicator light built into the N switch is displayed in red. P is displayed on the instrument panel. The gearbox shifts into Park position (P).

Note: when the engine is switched off using the engine Stop button, (P) position is automatically engaged, along with the electronic parking brake on equipped vehicles. The indicator light on the N control lights up in red and P is displayed on the instrument panel.



When you select position (D), (M) or (R), the vehicle moves forward as soon as you release the brake pedal (without pressing on the accelerator pedal).



Check that the P indicator light on the instrument panel and the red indicator light built into the N switch are displayed before you exit the vehicle.

Risk of loss of immobilisation of the vehicle



If the "WARNING: Check Gearbox" or "WARNING: Electric System" message is displayed or if the battery is faulty, immobilise the vehicle using the electronic parking brake. Contact your approved Dealer as soon as possible;

GEAR CONTROL

To engage neutral (N)

With the vehicle stationary and the engine running, press the brake pedal and briefly press the N switch (the built-in indicator light on the N switch lights up in white and N is displayed on the instrument panel).

Note: when position (R), (M) or (D) is engaged, it is not necessary to press the brake pedal in order to engage (N) position.



An impact to the underside of the vehicle while manoeuvring (e.g. striking a post, raised kerb or other street furniture) may result in damage to the vehicle (e.g. deformation of an axle). To avoid any risk of accident, have your vehicle checked by an approved dealer.

Drive in automatic mode: (D) position

With the vehicle stationary, the engine running and position (P), (N) or (R) engaged, press the brake pedal and **briefly press the D** switch (the indicator light built into the D switch

lights up in white and D is displayed on the instrument panel).

If one of these conditions is not met, the D indicator light flashes for approximately five seconds and the indicator light **3** stays on the instrument panel.

Note: with the engine running, the vehicle moving and (D) position engaged, it is possible to switch to manual driving mode (M) simply by pressing the D switch once (the indicator light built into the D switch lights up in blue and M is displayed on the instrument panel).

For most road conditions, you will not need to touch the switches: the gears will change automatically and optimally according to the degree to which the accelerator pedal is pressed, the driving style chosen and the road type.

Note: with the engine running and the vehicle travelling at between approximately 0 and 6 mph (0 and 10 km/h), in (N) or (R) position, it is not necessary to press the brake pedal to engage (D) position. This is useful during parking manoeuvres requiring a number of alternate forward and reverse movements.



When you select position (D), (M) or (R), the vehicle moves forward as soon as you release the brake pedal (without pressing on the accelerator pedal).

Economical driving

When driving, always leave the gearbox in (D) position and press the accelerator pedal only slightly to ensure automatic gear changes at a lower engine speed.

Accelerating and overtaking

Depress the accelerator pedal briskly and fully (so that it goes beyond the kickdown point).

This will enable you to change down to the optimum gear within the engine range.

Driving in temporary manual mode

The temporary manual mode can be used when automatic mode (D) **has previously been engaged.**

It is possible to force gear changes (temporary manual mode), by operating the paddles:

– to shift down through the gears, press the left-hand paddle;

GEAR CONTROL

– to move up through the gears, press the right-hand paddle.

The gear selected is displayed on the instrument panel.

Note: the gearbox returns to automatic driving mode:

- if no action has been taken on either of the paddles for more than five seconds;
- if you press the D switch again;
- If you press and hold the right-hand paddle.

Special cases

In certain driving conditions (e.g. engine protection mode, operation of the electronic stability control: ESC, etc.), the automatic system may change the gear automatically.

The requested gear will be maintained for a period set by the system, based on the gradient and the driving style.

The automatic system **will take over once this period has elapsed and may then trigger an automatic gear change.**

Likewise, to prevent incorrect manoeuvres, a gear change **may be refused by the automatic system: in this case the engaged gear flashes** on the instrument panel for a few seconds as a warning.



When facing uphill, to remain stopped, do not keep your foot on the accelerator.

Risk of overheating the automatic gearbox.

Driving in manual mode: (M) position

With the vehicle stationary, the engine running and position (P), (N) or (R) engaged, press the brake pedal **and briefly press the D switch (the indicator light built into the D switch lights up in white and D is displayed on the instrument panel). To switch to (M) position, briefly press again on the D switch (the indicator light built into the D switch lights up in blue and M is displayed on the instrument panel).**

Repeatedly shifting the paddles allows you to change gears manually:

- to shift down through the gears, press the left-hand paddle;
- to move up through the gears, press the right-hand paddle.



The gear selected is displayed on the instrument panel.

Note: with the engine running, the vehicle moving and (M) position engaged, you can switch to automatic mode (D) simply by pressing the D switch once (the indicator light built into the D switch lights up in white and D is displayed on the instrument panel).

Gear changing threshold indicator

When the indicator light **6** is displayed on the instrument panel:

- in white with a dash, this indicates that the gear engaged complies with the engine speed;

GEAR CONTROL

2

– in red with  accompanied by a beep, this indicates the need to shift up a gear;

– with , this indicates the need to change to a lower gear.



In "Track" mode, the gearbox changes to permanent manual mode

(M).

To change to automatic driving mode (D), select "Normal " or "Sport" mode (see "Choice of driving mode" in Section 2).

Special cases

In certain driving cases (e.g. engine protection, etc.), a gear change can be performed automatically in the event of over-revving or approaching under-revving. The manual mode remains activated.

Similarly, to avoid making an incorrect move, a gear change may be refused by the gearbox. In this case, the display for the engaged gear flashes for a few seconds to warn you.

Multiple downshifting

Depending on the vehicle and the if the "Sport" or "Track" driving mode is activated (refer to the "Choice of driving mode" in Section 2), it may be possible to quickly downshift several gears.

With the gearbox in (M) position and braking, press and hold the left-hand paddle as many times as is necessary for the gears to automatically descend to the optimal gear.

Parking the vehicle

When the engine is switched off by pressing the button, (P) is automatically engaged as well as the electronic parking brake, on vehicles equipped with it. The indicator light on the N control lights up in red and P is displayed on the instrument panel.

With the vehicle stationary and the engine running, **press and hold the N** switch until the indicator light built into the N switch lights up in red. The gearbox shifts to Park (P) position.

Special case

As (P) position is automatically engaged when the engine is stopped, it is sometimes necessary to set the gearbox to (N) position, for example in some car washes or when the vehicle is being transported.



Never leave your vehicle without setting the gearbox to P position and switching off the

engine.

This is because when the vehicle is stationary with the engine running and a gear engaged, the vehicle may begin to move.

There is a risk of accidents.

With the engine off, the ignition on, the doors closed and the gearbox in (P) position, it is possible to switch to (N) position by briefly pressing the N switch while simultaneously pressing the brake pedal (the indicator light built into the N switch lights up in white and N is displayed on the instrument panel).

The (N) position can be engaged before the driver's door is opened and no later than 45 seconds after the engine is stopped. After this time or after opening the driver's door, it will be necessary to turn on the ignition again to disengage (P) position.

Note: once engaged after the engine is stopped, the (N) position is maintained until the vehicle ignition is switched on again.

GEAR CONTROL



Special feature related to the "Stop and Start" function: if you are going to unfasten the driver's seat belt **before the engine goes on standby due to the " Stop and Start " function, make sure that the (P) position is engaged. The P indicator light appears on the instrument panel as confirmation. Risk of loss of immobilisation.**



If information disappears from the instrument panel, stop and immobilise the vehicle using the electronic parking brake or by engaging (P) position by pressing and holding the N switch (the indicator light built into the N switch lights up in red when the engine is on).

To select reverse gear

With the vehicle stationary and the engine on, engage position (P), (N), (M) or (D), press the brake pedal and

briefly press the R switch (the indicator light built into the R switch lights up in white and R is displayed on the instrument panel).

The reversing lights will come on as soon as the reverse gear is selected (ignition on) and, depending on the vehicle, the reversing camera will be activated (refer to "Reversing camera" in Section 2).

If the brake pedal is not pressed down, the R indicator light flashes for approximately five seconds and the **3** warning light stays on the instrument panel.

Note: with the engine running and the vehicle travelling at between approximately 0 and 6 mph (0 and 10 km/h), in (N) or (D) position, it is not necessary to press the brake pedal to engage (R) position. This is useful during parking manoeuvres requiring a number of alternate forward and reverse movements.

Special circumstances

If the road surface and bends do not allow you to stay in automatic mode (e.g. when driving in the mountains), we recommend that you change to manual mode.

This will prevent the automatic gearbox from changing gear

repeatedly when climbing, and permit engine braking on long descents.

Maintenance period

Refer to the maintenance document for your vehicle or consult an Approved Dealer to check whether the automatic gearbox requires scheduled maintenance.

If it does not need to be serviced, there is no need to top up the oil.

Operating faults

– **when driving**, if the "WARNING: Check Gearbox" message appears on the instrument panel, this indicates a fault.

Immobilise the vehicle using the electronic parking brake.

Contact an approved dealer as soon as possible;

– **when driving**, if the "WARNING: Gearbox Overheating" message appears on the instrument panel, stop as soon as possible to let the gearbox cool down and wait for the message to disappear;

– **if a vehicle with an automatic gearbox breaks down**, refer to the information on "Towing" in Section 5.

GEAR CONTROL

2



For safety reasons, do not switch off the ignition before the vehicle has come to a complete standstill.

SPECIAL FEATURES OF PETROL VERSIONS

The following operating conditions:

- driving for long periods when the low fuel level warning light is lit;
- "Sporty" driving or driving in extreme conditions (e.g. driving fast around corners, etc.) with minimum fuel level warning light lit;
- using leaded petrol;
- using fuel or lubrication additives which are not approved.

Or operating faults such as:

- a faulty ignition system, running out of fuel or disconnected spark plugs resulting in the engine misfiring or jerkiness while driving;
- loss of power;

as they may cause the catalytic converter to overheat and thus reduce its efficiency, **or damage it irreparably and cause heat damage to the vehicle.**

If you notice any of the above operating faults, have the necessary repairs carried out as soon as possible by an approved dealer.

These faults may be avoided by regularly taking your vehicle to an approved dealer at the intervals specified in the maintenance document.

Starting problems

To avoid damaging the catalytic converter or the starter, and to prevent premature wearing of the battery, **do not keep trying to start the engine (using the start button, or by pushing or towing the vehicle) without having identified and corrected the starting fault.**

If the fault cannot be identified, do not keep trying to start the engine, but contact an approved Dealer.



Do not park the vehicle or run the engine in locations where combustible substances or materials such as grass or leaves can come into contact with the hot exhaust system.

Particle filter

The particle filter is used in the treatment of exhaust gases from petrol engines.

Depending on the vehicle, the warning light  displayed on the instrument panel indicates that the filter is becoming clogged and requires

cleaning. In this case, when the  warning light appears, as soon traffic conditions and speed limits allow, drive between 50 mph (80 km/h) and 68 mph (110 km/h) until the light goes out.

The warning light should go out after approximately 20 minutes.

Note: the warning light may go out after 20 minutes if the driving conditions required to clean the filter are not fully met.

If the vehicle is stopped before the warning light disappears you will have to restart the process from the beginning.

If the filter becomes saturated, the



warning light and, depending

on the vehicle, the  warning light appears on the instrument panel accompanied by the "Check injection" message. In this case, please consult an Authorised Dealer.

If the **STOP** warning light and,

depending on the vehicle, the  warning light appear accompanied by the "WARNING: Engine Failure Risk" message, stop the vehicle and contact an approved dealer.

SPECIAL FEATURES OF PETROL VERSIONS

2



For your own safety, the **STOP** warning light requires you to stop immediately, as soon as traffic conditions allow. Switch off the engine and do not restart it. Call an approved Dealer.

PARKING BRAKE

Electronic parking brake

Assisted operation

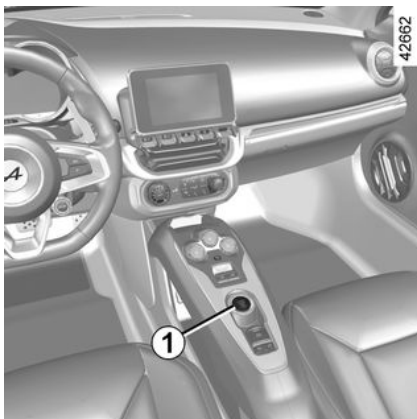

Applying the electronic parking brake

With the vehicle stationary, the electronic parking brake immobilises the vehicle when the engine start/stop button is pressed **1**.

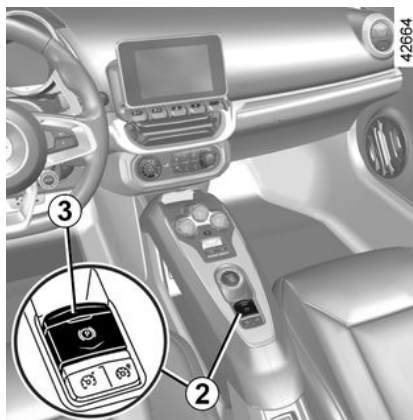

In all other cases, for example, **stalling of the engine or the engine going on standby as a result of the Stop and Start function** (refer to "Starting, stopping the engine" and "Stop and Start function" in Section 2), the electronic parking brake is not applied automatically.

Manual mode must be used.

For certain country-specific model versions, the assisted brake application function is not activated. See the information on "Manual operation".

To confirm that the electronic parking brake is applied, the "Parking Brake

ON" message and the "  " warning

light appear on the instrument panel and the indicator light **3** lights up on the switch **2**.

After the engine is switched off, the indicator light **3** goes out a few minutes after the electronic parking

brake has been applied and the  warning light goes out when the vehicle is locked.

Note: to indicate that the electronic parking brake is released, a beep sounds and the "WARNING: Apply Parking Brake" message appears on the instrument panel:

- with the engine on: when the driver's door is opened;
- with the ignition switched off (e.g. if the engine stalls): when a door is opened.

In this case, pull and release the switch **2** to apply the electronic parking brake.

Assisted release of the parking brake

The brake will be released as soon as the vehicle starts and accelerates.

2

PARKING BRAKE

2



Special feature related to the Stop and Start function: if the driver's seat belt is unfastened

before the engine goes on standby due to the Stop and Start function, make sure that the parking brake is applied: the

 warning light appears on the instrument panel to confirm this.

Risk of loss of immobilisation.



The electronic parking brake can be used to immobilise the vehicle.

Before leaving the vehicle, check that the electronic parking brake is fully applied. Application of the parking brake is confirmed by the illumination of the indicator light **3** on the switch

2 and the  warning light on the instrument panel until the doors are locked. Depending on the vehicle, a label may be located at the top of the windscreen to remind you.

Brief stop

To apply the electronic parking brake manually (when stopping at a red light, stopping when the engine is running, etc.): pull and release the switch **2**.

The brake is released as soon as the vehicle is started up again.

Manual operation

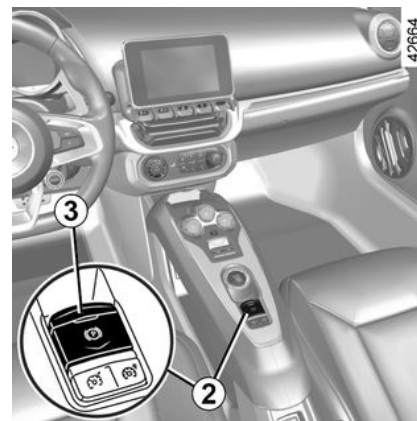

You can apply the electronic parking brake manually.

Manually applying the electronic parking brake

Pull the switch **2**. Warning light **3** and warning light  on the instrument panel light up.

Manually releasing the electronic parking brake

With the ignition on, press the brake pedal then press the switch **2**: the

warning light **3** and the  warning light disappear.

PARKING BRAKE

Special cases



To park, with the electronic parking brake released (if there is a risk of freezing, for example):

- stop the engine by pressing the engine Start/Stop button **1**;
- check that the N switch indicator lights up in red and that the Park position P warning light is displayed on the instrument panel;
- depress the brake pedal then release the electronic parking brake manually.

For vehicles fitted with the Stop and Start function, with the engine on standby, the electronic parking brake is automatically activated if the driver

unfastens their seat belt or opens the driver's door or gets out of their seat.



If the "WARNING: Electric System" or "Check battery" or "WARNING: Braking System" message appears, you must immobilise the vehicle, engaging the first gear (on a manual gearbox) or P position (on an automatic gearbox).

If the conditions and the slope require it, chock the wheels of the vehicle.

Risk of loss of immobilisation of the vehicle.

Call an approved Dealer.



Never leave your vehicle without setting the gearbox to P position and switching off the engine. This is because when the vehicle is stationary with the engine running and a gear engaged, the vehicle may begin to move.

There is a risk of accidents.

For safety reasons, the automatic release is deactivated when the driver's door is open or not shut properly, the driver's seatbelt is not fastened and the engine is running (in order to prevent the vehicle from moving without the driver).

The "Release Parking Brake" message appears on the instrument panel when the driver presses the accelerator pedal.

PARKING BRAKE

2





If no lights or sounds are apparent, this indicates a fault in the instrument panel. This indicates that it is essential to stop immediately (as soon as traffic conditions allow). Ensure that the vehicle is correctly immobilised and contact an approved Dealer.



It is therefore essential to immobilise the vehicle by setting the gearbox to P position. Depending on the slope, chock the vehicle.

Operating faults

– If there is a fault, the  warning light illuminates on the instrument panel accompanied by the "Check Parking Brake" message and,

in some cases, the  warning light.

Contact your approved Dealer straight away.

– If there is an electronic parking

brake fault, the  warning light comes on, along with the "WARNING: Braking System" message, a beep

and, in some cases, the  warning light.

This means that you must stop as soon as traffic conditions allow.

ENVIRONMENT

Your vehicle has been designed with respect for the **environment** in mind for its entire service life: during its production, usage and at the end of its service life.

Manufacture

Your vehicle has been manufactured at a factory which complies with a policy to reduce the environmental impact on the surrounding areas (reduction of water and energy consumption, visual and noise pollution, atmospheric emissions and waste water; sorting and reusing waste).

Emissions

For the usage phase, your vehicle was designed to emit fewer greenhouse gases (CO₂) and therefore to consume less fuel.

Our vehicles are also equipped with a particle filter system including a catalytic converter, an oxygen sensor and an active carbon filter (the latter prevents vapour from the fuel tank being released into the open air).

Please make your own contribution towards protecting the environment too.

- Worn parts replaced in the course of routine vehicle maintenance (vehicle battery, oil filter, air filter, batteries, etc.) and oil containers (empty or filled with used oil) must be disposed of through specialist organisations.
- At the end of the vehicle's service life, it should be sent to approved centres to ensure that it is recycled.
- In all cases, comply with local legislation.

Recycling

Your vehicle is at least 85% recyclable and at least 95% recoverable.

To achieve these objectives, many of the vehicle components have been designed to enable them to be recycled. The materials and structures have been carefully designed to allow these components to be easily removed and reprocessed by specialist companies.

In order to preserve raw material resources, this vehicle incorporates numerous parts made from recycled plastics or renewable materials (vegetable or animal-derived materials such as cotton or wool).

MAINTENANCE AND ANTIPOLLUTION ADVICE

2

Your vehicle complies with criteria for recycling and recovering vehicles at the end of their service life, which entered into force in 2015.

Some of the parts on your vehicle have been designed to be recycled later.

These parts are easily removable in order to be collected and reprocessed in recycling networks.

Furthermore, by virtue of its design, moderate fuel consumption and initial settings, your vehicle also conforms to current anti-pollution regulations. The manufacturer is actively striving to reduce pollutant exhaust gas emissions and to save energy. But the fuel consumption of your vehicle and the level of pollutant exhaust gas emissions are also your responsibility. Ensure that it is maintained and used correctly.

Maintenance

It is important to remember that failure to respect antipollution regulations could lead to legal action being taken against the vehicle owner.

In addition, replacing engine, fuel supply system and exhaust components with parts other than those originally recommended by the manufacturer may alter your vehicle so

that it no longer complies with antipollution regulations.

Have your vehicle adjusted and checked by an approved dealer, in accordance with the instructions given in your maintenance schedule: they will have all the equipment necessary for ensuring that your vehicle is maintained to its original standard.

Engine adjustments

- **Spark plugs:** for optimum fuel economy, efficiency and performance, the specifications which have been laid down by our Design Department must be strictly applied.

If the spark plugs have to be changed, use the make, type and gap specified for your vehicle's engine. Contact an authorised dealer for this.

- **Air filter, fuel filter:** a choked element hinders performance. It must be replaced.
- **Ignition and idle speed:** no adjustment is needed.

Exhaust gas monitoring system

The exhaust gas monitoring system will detect any operating faults in the vehicle's exhaust gas antipollution system.

If this system malfunctions, toxic substances may be released into the

atmosphere or mechanical damage may occur.



This indicator light on the instrument panel indicates possible faults in the system:

This lights up when the ignition is switched on and goes out when the engine is started.

- If it lights up continuously, contact an approved dealer as soon as possible;
- If it flashes, reduce the engine speed until the light stops flashing. Contact your approved Dealer as soon as possible;

DRIVING ADVICE, ECO-DRIVING

Fuel consumption is accredited in accordance with a standard regulatory method. Identical for all manufacturers, this enables vehicles to be compared with one another.

Consumption in real time depends on vehicle usage conditions, the equipment fitted and the user's driving style. To optimise fuel consumption, please refer to the following advice.

Depending on the vehicle, there may be different functions available to help you reduce your fuel consumption:

- the rev counter;
- the gear change indicator;
- the Stop and Start function (refer to the information on the "Stop and Start function" in Section 2).

If fitted on the vehicle, the navigation system provides additional information.

Gear change indicator 1



To obtain optimum consumption levels, in manual mode a warning light on the instrument panel lets you know the best time to move up or down a gear:

 shift up a gear;

 downshift a gear.

Driving advice and ECO driving

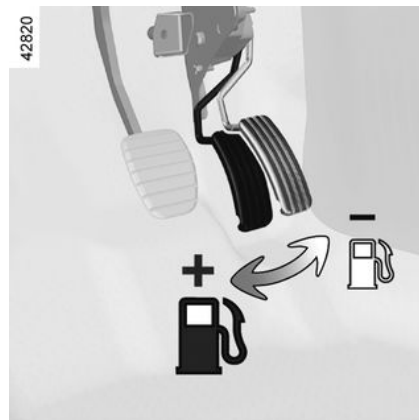

Behaviour

- Drive carefully until the engine reaches its normal operating temperature, rather than let it warm up while the vehicle is stationary.
- High speeds significantly affect the vehicle's fuel consumption.

Examples (at a steady speed):

- reducing the speed from approximately 80 mph (130 km/h) to 68 mph (110 km/h) saves up to around 20% of fuel;
- reducing the speed from approximately 56 mph (90 km/h) to 50 mph (80 km/h) saves up to around 10% of fuel.

DRIVING ADVICE, ECO-DRIVING

2

- "Sporty" driving uses a lot of fuel: go easy on the throttle. "Normal" driving mode is recommended (refer to "Choice of driving mode" in Section 1).
- Do not over rev the engine in the intermediate gears.

You should always use the highest gear possible.

- Avoid sudden acceleration.
- Brake as little as possible. If you anticipate an obstacle or bend in advance, you may then simply release the accelerator pedal.
- Accelerating before switching off the engine is unnecessary for modern vehicles.
- Bad weather, flooded roads:



Do not drive through water if it is higher than the lower edge of the wheel rim.

Heating levels

It is normal to notice an increase in the vehicle's fuel consumption when using the heating (particularly when the outside temperature drops below zero) or air conditioning.



Driver obstruction

On the driver's side, only use mats suitable for the vehicle, attached with the pre-fitted components, and check the fitting regularly. Do not lay one mat on top of another.

There is a risk of wedging the pedals



26528



Tyres

- An underinflated tyre increases fuel consumption.
- We recommend the highest speed tyre pressure or the pressure recommended to optimise fuel

consumption as indicated at the bottom of the driver's door (please refer to "Tyre inflation pressure" in Section 4).

- The use of non-recommended tyres can increase fuel consumption.

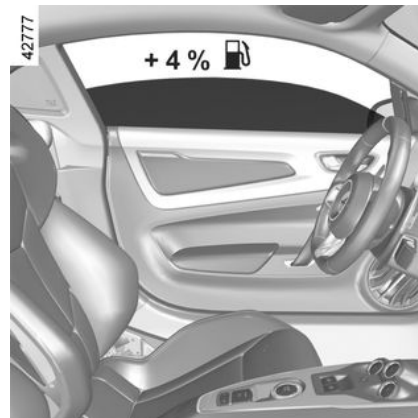

Advice on use

- Electricity is fuel – switch off all the electrical components when they are not genuinely needed. **However** (safety first), keep your lights on when the visibility is bad ("see and be seen").
- Use the air vents. Driving with the windows open at 62 mph (100 km/h) will increase fuel consumption by 4%.
- Never fill the fuel tank right to the brim to avoid overflow.

DRIVING ADVICE, ECO-DRIVING

– **On vehicles equipped with air conditioning**, switch off the air conditioning when it is not required.

Advice for reducing consumption and helping to preserve the environment:

If the vehicle has been parked in the sun, open the doors for a few moments to let the hot air escape before starting the engine.

– Avoid using the vehicle for "door-to-door" calls (short journeys with long waits in between) because in such conditions the engine never reaches its optimal operating temperature.

TYRE PRESSURE MONITORING SYSTEM

2



When fitted to the vehicle, this system notifies the driver if one or more tyres lose pressure.



This function is an additional driving aid. The function does not take the place of the driver. It cannot, therefore, under any circumstances replace the vigilance or the responsibility of the driver. Check the tyre pressures, including the emergency spare wheel, once a month.

Operating principle

Each wheel (except for the emergency spare wheel if fitted) has a sensor in the inflation valve which periodically measures the tyre pressure during driving.

Warning light  1 comes on steady to alert the driver in the event of insufficient pressure (deflated wheel, punctured tyre, etc.).

Resetting the standard level for the tyre pressures

This should be performed:

- when the standard tyre pressure needs to be changed to adapt to usage conditions (empty, carrying a load, motorway driving, etc.);
- after swapping a left-hand/right-hand wheel (this practice is not recommended);
- after changing a wheel.

It should always be done after checking the tyre pressure of all four tyres when cold.

Tyre pressures must correspond to the current usage of the vehicle (empty, carrying a load, motorway driving, etc.).

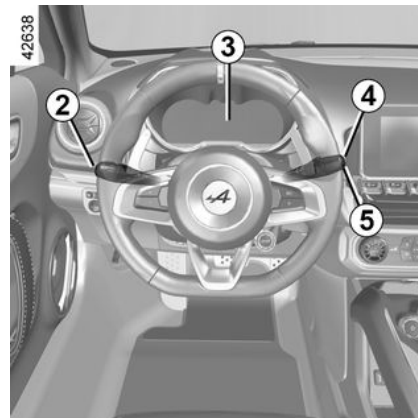

Resetting procedure

Conditions for launching the reset:

- ignition on;
- vehicle stationary;
- tyre pressure above 1.6 bar (refer to the information on "Tyre pressure" in Section 4).



If the tyre pressure resetting conditions are not met, the "Tyre pressure SET unavailable" message will be displayed on the instrument panel.

To reset:

TYRE PRESSURE MONITORING SYSTEM

– press button **4** or **5** to select the trip parameters, then use the button **2** to browse to the "Tyre pressure: SET (press and hold)" function on the display **3**;
– press and hold (for around three seconds) on button **2**, **4** or **5** to start resetting. The "Learning Tyre Pressures" message is displayed for approximately five seconds. The request to reset the reference tyre pressure value has been taken into account.

Reinitialisation is carried out after a few minutes' driving.

Note: the tyre pressure value cannot be less than that recommended and indicated on the edge of the driver's door or, depending on the vehicle, on the bottom of the driver's door.

Display

The **3** symbol appears on the instrument panel in the event of any tyre pressure faults (flat tyre, punctured tyre, etc.).

« Adjust Tyre Pressure »

The  warning light appears and stays on, accompanied by the "Adjust Tyre Pressure" message. This indicates that at least one tyre is flat.

Check and, if necessary, readjust the pressures of the four wheels when cold. The warning light  goes off after a few minutes' driving.

« Puncture »

The  warning light appears and stays on, accompanied by the "Puncture" message and a beep.

This message appears along with the

 warning light.

They indicate that at least one wheel is punctured or severely underinflated. Replace it or contact an approved dealer if it is punctured. Top up the tyre pressure if the wheel is deflated.

 The sudden loss of pressure in a tyre (burst tyre, etc.) cannot be detected by the system.



For your own safety, the

 warning light requires you to stop immediately, as soon as traffic conditions allow.

« Check Tyre Pressure Sensors »

The  warning light flashes for a few seconds, then appears and stays on, accompanied by the "Check Tyre Pressure Sensors" message.

This message appears along with the

 warning light.

They indicate that at least one tyre is not fitted with sensors (e.g. emergency spare wheel). In other cases, contact an authorised dealer.

Readjustment of tyre pressures

The pressures must be adjusted when cold (refer to the label on the edge of the driver's door or, depending on the vehicle, on the bottom of the driver's door).

If the pressure cannot be checked when the tyres are **cold**, the **recommended pressures should be increased by 0.2 to 0.3 bar (3 PSI)**.

TYRE PRESSURE MONITORING SYSTEM

Never deflate a hot tyre.

Replacing wheels/tyres

This system requires specific equipment (wheels, tyres, etc.). Please see the information on "Tyres" in Section 5.

Contact an approved dealer to replace the tyres and to find out about accessories compatible with the system that are available from the brand's Network: using any other accessory could affect the correct operation of the system.

Emergency spare wheel

If the vehicle is equipped with an emergency spare wheel, it will not have a sensor.

Tyre repair product and inflation kit

Because the valves are specially designed, only use equipment approved by the approved network. Please refer to "Tyre inflation kit" in Section 5.

2

DRIVER CORRECTION DEVICES AND AIDS

- ABS (anti-lock braking system);
- ESC (electronic stability control) with understeer control and traction control;
- emergency brake assist;
- hill start assistance.

Other driving assistance systems are detailed on the following pages.



These functions are an additional aid in the event of critical driving conditions, enabling the vehicle behaviour to be adapted to suit the driving conditions. However, the functions do not take the place of the driver. **They do not increase the vehicle's limits and should not encourage you to drive more quickly.** Therefore, they can under no circumstances replace the vigilance or responsibility of the driver when manoeuvring the vehicle (the driver must always be ready for sudden incidents which may occur when driving).

ABS (anti-lock braking system)

Under heavy braking, the ABS prevents the wheels from locking, allowing the stopping distance to be managed and keeping control of the vehicle.



Under these circumstances, the vehicle can be steered to avoid an obstacle whilst braking. In addition, this system can increase stopping distances, particularly on roads with low surface grip (wet ground etc.).

You will feel a pulsation through the brake pedal each time the system is activated. The ABS does not in any way improve the vehicle's "physical" performance relating to the road surface and roadholding. It is still **essential** to follow the rules of good driving practice (such as driving at a safe distance from the vehicle in front etc.).



In an emergency, apply **firm and continuous pressure** to the brake pedal. There is no need to pump it repeatedly. The ABS will modulate the force applied in the braking system.

Operating faults:

–  and  lit up on the instrument panel, accompanied by the "Check ABS", "WARNING: Check Braking System" and "Check ESC" messages: the ABS, ESC and emergency brake assist are deactivated. **Braking is still provided;**

– , ,  and

STOP lit on the instrument panel accompanied by the "WARNING: Braking System" message: **this indicates a fault with the braking system.**

In both cases, please consult an Authorised Dealer.



Your braking systems are partially operational. However, it is **dangerous to brake suddenly** and it is essential to stop immediately, as soon as traffic conditions allow. Call an approved Dealer.

DRIVER CORRECTION DEVICES AND AIDS

Electronic stability control ESC with understeer control and traction control

Electronic stability control ESC

This system helps you to keep control of the vehicle in critical driving conditions (avoiding an obstacle, loss of grip on a bend, etc.).

Operating principle

A sensor in the steering wheel detects the direction selected by the driver.

Other sensors throughout the vehicle measure the actual direction.

The system compares driver input to the actual trajectory of the vehicle and corrects the trajectory if necessary by controlling the braking of certain wheels and/or engine power. In the event that the system is engaged,

indicator light  flashes on the instrument panel.

Understeer control

This system optimises the action of the ESC in the case of pronounced understeering (loss of front axle road holding).

Traction control

This system helps to limit wheelspin of the drive wheels and to control the

vehicle when pulling away accelerating or decelerating.



Operating principle

Using the wheel sensors, the system measures and compares the speed of the drive wheels at all times and slows down their over-rotation. If a wheel is starting to slip, the system brakes automatically until the drive supplied becomes compatible with the level of grip under the wheel again.

The system also adjusts the engine speed to the grip available under the wheels, independently of the pressure exerted on the accelerator pedal.

Operating faults

When the system detects an operating fault, the "Check ESC" message and

the  and  warning lights appear on the instrument panel. In this case, the ESC and traction control system are deactivated.

Consult an approved dealer.

ESC and traction control in Track mode

After pressing and holding the switch **1** to select Track mode, the ESC functions can be modified and delay the driving assistance (refer to "Choice of driving mode" in Section 2).

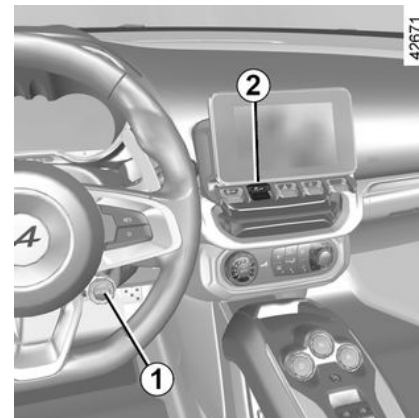

Disabling the ESC and traction control functions

In some situations (driving on very wet ground: snow, mud, or driving in Sport, Track mode, etc.), you can disable these functions by pressing and holding the switch **2**.

The  warning light and the "ESC OFF" message are displayed on the instrument panel to warn you.

You can reactivate these functions at any time by briefly pressing the switch **2**.

DRIVER CORRECTION DEVICES AND AIDS



Any change of driving mode implemented by pressing the switch **1** reactivates the ESC and traction control functions (refer to "Choice of driving mode in Section 2).

Emergency brake assist

This system supplements the ABS and helps reduce vehicle stopping distances.

Operating principle

The system is for detecting an emergency braking situation. In this case, the braking assistance immediately develops maximum power and may trigger ABS regulation.

ABS braking is maintained as long as the brake pedal is applied.

Hazard warning lights switching on

Depending on the vehicle, these may light up in the event of sudden deceleration.

Braking anticipation

Depending on the vehicle, when you rapidly release the accelerator, the system anticipates the braking manoeuvre in order to reduce stopping distances.

Special cases

When using the cruise control:

- if you use the accelerator pedal when you release it, the system may be triggered;
- if you do not use the accelerator, the system will not be triggered.

Operating faults

When the system detects an operating fault, the "WARNING: Check Braking System" appears on the instrument

panel along with the  warning light.

Consult an approved dealer.



These functions are an additional aid in the event of critical driving conditions, enabling the vehicle behaviour to be adapted to suit the driving conditions. The functions do not take the place of the driver. **They do not increase the vehicle's limits and should not encourage you to drive more quickly.** Therefore, they can under no circumstances replace the vigilance or responsibility of the driver when manoeuvring the vehicle (the driver must always be ready for sudden incidents which may occur when driving).

Hill start assistance

Depending on the gradient of the incline, this system assists the driver when starting on a hill. It prevents the vehicle from rolling backwards by automatically applying the brakes when the driver lifts his/her foot off the brake pedal to depress the accelerator pedal.

System operation

DRIVER CORRECTION DEVICES AND AIDS

2

It only operates when the gearbox is in D position and the vehicle is completely stationary (brake pedal pressed).

The system holds the vehicle for approximately **2 seconds**. The brakes are then gradually released (the vehicle will move according to the slope).



The hill start assistance system cannot completely prevent the vehicle from rolling

backwards in all situations (extremely steep gradients etc.). In all cases, the driver may depress the brake pedal to prevent the vehicle from rolling backwards.

The Hill Start Assist function should not be used for prolonged stops: use the brake pedal.

This function is not designed to immobilise the vehicle permanently.

If necessary, use the brake pedal to stop the vehicle.

The driver must remain particularly vigilant when driving on slippery or low-grip surfaces.

Risk of serious injury.

SPEED LIMITER



The speed limiter function helps you stay within the driving speed limit that you choose, known as the **limit speed**.

Controls

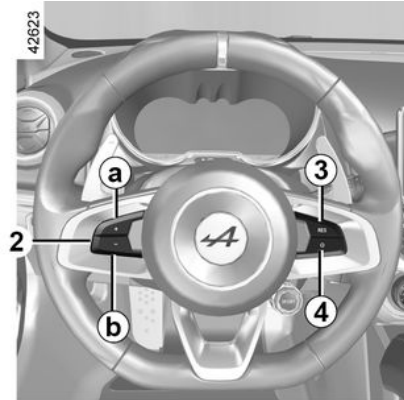

1. Main "On/Off" switch.
2. Controls for:
 - a. activate, store and increase the limited speed (+) ;
 - b. decrease the limited speed (-).
3. Activation and recall of stored limited speed (RES).
4. Puts the function on standby and stores the limited speed (0).

Switching on

Press the switch **1** on the  side.

The  indicator light appears in orange on the instrument panel,

accompanied by dashes to indicate that the speed limiter function is activated and waiting to store a limited speed.

To store the current speed, press switch **2** on side **a** (+): the limited speed replaces the dashes.

The minimum speed that can be stored is 19 mph (30 km/h).

Driving

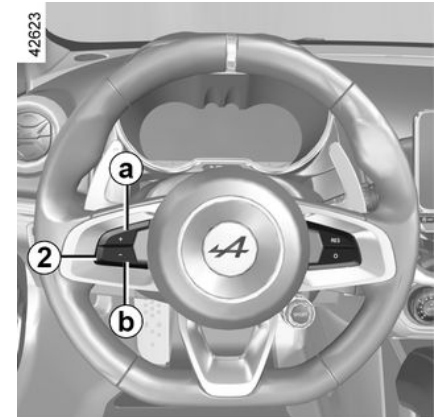

When a limited speed has been stored and this speed is not reached, driving is similar to driving a vehicle without the speed limiter function.

Once you have reached the stored speed, no effort on the accelerator pedal will allow you to exceed the

SPEED LIMITER

programmed speed except in an emergency (refer to information on "Exceeding the limit speed").

Varying the limit speed

The limited speed setpoint can be changed by repeatedly pressing the switch **2**:

- on side **a** (+) to increase the speed;
- on side **b** (-) to decrease the speed.



The speed limiter function is in no way linked to the braking system.

Exceeding the limit speed

It is possible to exceed the limit speed at any moment. To do this, press the accelerator pedal **firmly down** beyond the point of resistance.

While the speed is being exceeded, the speed limiter flashes red on the instrument panel.

Then, release the accelerator pedal: the speed limiter function will return as soon as you reach a speed lower than the memorised speed.

Limited speed cannot be maintained

When driving down a steep gradient, the system is unable to maintain the limited speed: the stored speed will flash in red on the instrument panel and a beep sounds at regular intervals to inform you of this situation.

Putting the function on standby

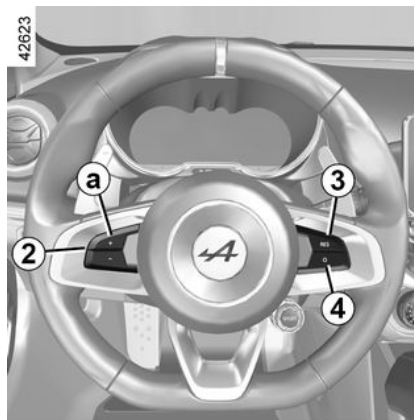

The speed limiter function is suspended when you press switch **4** (0). In this case, the limited speed remains stored and the stored speed appears on the instrument panel.

Recalling the limit speed

If a speed has been stored, it can be recalled by pressing the switch **3** (RES).



When the speed limiter is on standby, press side **a** (+) of the switch **2** to reactivate the function without taking into account the stored speed: the current vehicle speed is registered.

Switching off the function



The speed limiter function is deactivated if you press switch **1**: in this case a speed is no longer stored. The orange instrument panel warning

light  goes out, confirming that the function is stopped.

CRUISE CONTROL



The cruise control function helps you to maintain your driving speed at a speed that you choose, called the **cruising speed**.

This cruising speed can be set at any speed above 19 mph (30 km/h).



The cruise control function is in no way linked to the braking system.

Controls

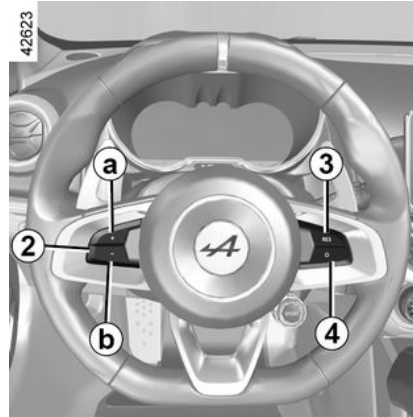

1. Main "On/Off" switch.
2. Controls for:
 - a. activate, store and increase the cruising speed (+);
 - b. decrease the cruising speed (-).
3. Activation with recall of saved cruising speed (RES).
4. Put the function on standby (with cruising speed stored) (0).



This function is an additional driving aid. It can under no circumstances replace the driver's responsibility to respect speed limits or to be vigilant. The driver must always be in control of the vehicle. Therefore, it can under no circumstances replace the driver's responsibility to respect speed limits and to be vigilant (the driver must always be ready to brake). Cruise control must not be used in heavy traffic, on winding or slippery roads (black ice, aquaplaning, gravel) and during bad weather (fog, rain, side winds etc.).

There is a risk of accidents.

CRUISE CONTROL

Switching on



Press the switch **1** on the  side.

The  warning light appears in green accompanied by dashes to indicate that the cruise control function is activated and waiting to store a cruising speed.

Activating cruise control

At a steady speed above approximately 19 mph (30 km/h), press the switch **2** on side **a** (+): the function is activated and the current speed is stored.

The cruising speed replaces the dashes and cruise control is confirmed by the appearance of the cruising speed in green and the warning light



If you try to activate the function below 19 mph (30 km/h), the function will remain inactive.

Driving

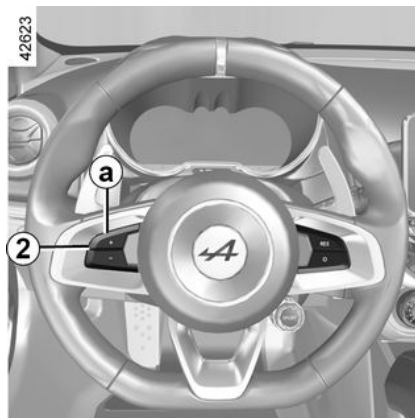

Once a cruising speed is memorised and the cruise control function is active, you may lift your foot off the accelerator pedal.



Please note that you must keep your feet close to the pedals in order to react in an emergency.

Adjusting the cruising speed

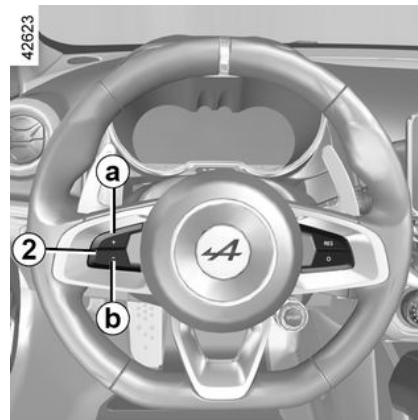

The cruising speed can be changed by pressing the switch **2** repeatedly:

- on side **a** (+) to increase the speed;
- on side **b** (-) to decrease the speed.

CRUISE CONTROL



The cruise control function is in no way linked to the braking system.

Exceeding the cruising speed

The cruising speed may be exceeded at any time by depressing the accelerator pedal. While overtaking, the cruising speed flashes red on the instrument panel.

Then, release the accelerator pedal: after a few seconds, the vehicle will automatically return to its set cruising speed.

Cruising speed cannot be maintained

When driving down a steep gradient, the system is unable to maintain the cruising speed: the stored speed will flash in red on the instrument panel information display to inform you of this situation.

Putting the function on standby

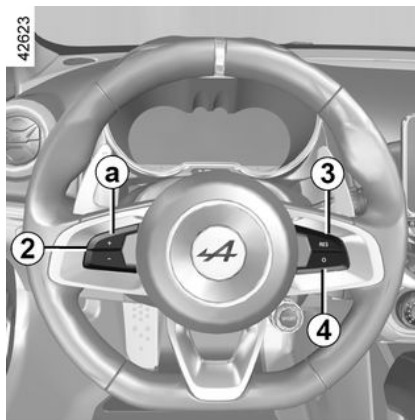

The function is set to standby if you:

- the switch **4** (0);
- the brake pedal;
- shift the gear to N position.

In all three cases, the cruising speed remains stored and this speed appears on the instrument panel.

Standby is confirmed by the display of the cruising speed in grey.

Returning to the cruising speed

If a speed is stored, it can be recalled, once you are sure that the road conditions are suitable (traffic, road surface, weather conditions, etc.). Press the switch **3** (RES) if the vehicle speed is above 19 mph (30 km/h).

When the stored speed is recalled, activation of the cruise control is confirmed by the illumination of the cruising speed in green.

Note: if the speed previously stored is much higher than the current speed, the vehicle will accelerate more rapidly to reach this threshold.



When the cruising speed is on standby, press side **a** (+) on the switch **2** to reactivate the cruise control function without taking into account the stored speed: it is the vehicle's current speed that is taken into account.

CRUISE CONTROL

Switching off the function

2



The cruise control function is deactivated if you press switch **1**: in this case a speed is no longer stored.

The green  indicator light switches off to confirm that the function is deactivated.



Putting the cruise control on standby or switching it off does not cause a rapid reduction in speed: you must brake by pressing the brake pedal.

PARKING AIDS

Parking distance control

Operating principle

Ultrasonic detectors, installed in the rear bumper and, depending on the vehicle, the front bumper, measure the distance between the vehicle and an obstacle.

This measurement is indicated by beeps which become more frequent the closer you come to the obstacle, until they become a continuous beep when the vehicle is approximately 30 centimetres from the obstacle.

The system detects obstacles to the rear and, depending on the vehicle, front of the vehicle.

The Park Assist system is only activated when the vehicle is driven at a speed below approximately 6 mph (10 km/h).



An impact to the underside of the vehicle while manoeuvring (e.g. striking a post, raised kerb or other street furniture) may result in damage to the vehicle (e.g. deformation of an axle). To avoid any risk of accident, have your vehicle checked by an approved dealer.

Location of the ultrasonic sensors



42673

Ensure that the ultrasonic sensors indicated by the arrows **1** are not obscured (by dirt, mud, snow, a badly

fitted/attached number plate), impacted, modified (including paintwork) or obstructed by any accessory fitted to the rear and/or, depending on the vehicle, to the front or sides of your vehicle.



This function is an additional driving aid. Under no circumstances should it replace the

driver's care or responsibility whilst reversing. The driver should always be ready for sudden incidents while driving: always ensure that there are no small, narrow moving obstacles (such as a child, animal, pushchair, bicycle, stone, post, etc.) in the blind spot when manoeuvring.

PARKING AIDS

2

A



42780

Note: display **A** shows the vehicle surroundings and emits beeps.

Operation

B



42778

Most objects located near the rear and, depending on the vehicle, front are detected.

Depending on the distance of the obstacle, the frequency of the beep will increase as it approaches and will become a solid beep at around 30 cm for obstacles to the front or rear. The green, orange and red zones will be shown on display **B** on the instrument panel.

Note: in the event of a change in trajectory during a manoeuvre, the risk of collision with an obstacle may be signalled with a delay.

Operating faults

Depending on the vehicle, when the system detects an operating fault, the "Check Park Assist" message appears on the instrument panel along with the



warning light. Consult an approved dealer.

Deactivating the system

You can deactivate Park Assist from the settings menu (refer to "Vehicle settings customisation menu" in Section 1).

Reversing camera

Operation



42678

PARKING AIDS

Depending on the equipment, when shifting into reverse gear, camera **1** transmits a view of the area behind the vehicle to the instrument panel or on the multimedia screen along with, depending on the vehicle, a moving guide line and a fixed guide line.

Note: you can adjust certain settings from the vehicle settings customisation menu (refer to "Vehicle settings customisation menu" in Section 1).

Special feature

Make sure that the camera is not obscured (by dirt, mud, snow, condensation etc.).



This function is an additional aid. It cannot, therefore, under any circumstances replace

the vigilance or the responsibility of the driver.

The driver should always be ready for sudden incidents while driving: always ensure that there are no small, narrow moving obstacles (such as a child, animal, pushchair, bicycle, stone, post, etc.) in the blind spot when manoeuvring.

35987

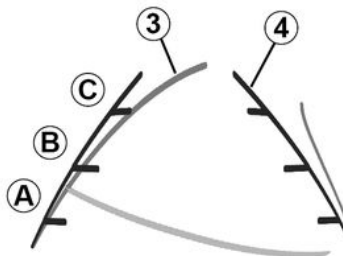

Moving guide line 3

(depending on the vehicle)

This is shown in orange on the multimedia screen **5**. It indicates the vehicle trajectory according to the position of the steering wheel.

Fixed guide lines 4

The fixed gauge includes coloured markers **A**, **B** and **C** indicating the distance behind the vehicle:

- **A** (red) at approximately 30 centimetres from the vehicle;
- **B** (white) approximately 60 centimetres from the vehicle;
- **C** (blue) approximately 120 centimetres from the vehicle.

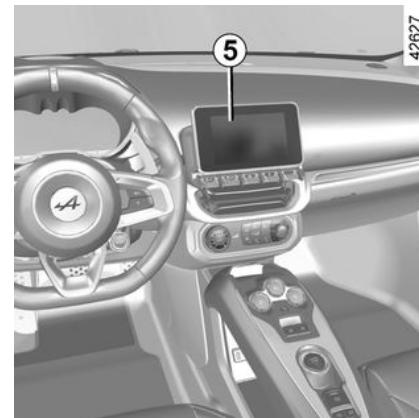

42627

2

This gauge remains fixed and indicates the vehicle trajectory if the wheels are in line with the vehicle.

This system is initially used with the aid of several gauges (mobile for trajectory and fixed for distance). When the red zone is reached, use the bumper image to stop accurately.

PARKING AIDS

2

i The screen shows a reverse image. The frames are a representation projected onto flat ground; this information must not be taken into account when superimposed on a vertical object or an object on the ground. Objects which appear on the edge of the screen may be deformed.

In very bright light (snow, vehicle in sunshine, etc.), the camera vision may be adversely affected. When the luggage compartment is open or not closed properly, the "Luggage compartment open" message appears and, depending on the vehicle, the camera display disappears.

Difference between the estimated distance and actual distance

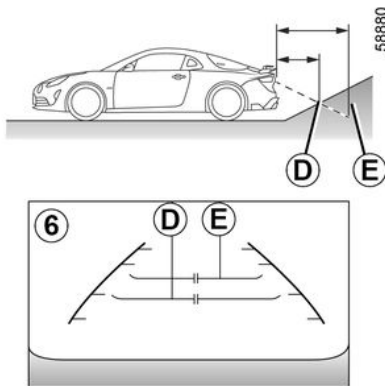

Reversing towards a steep uphill slope

The fixed guidelines **6** show the distances as closer than they actually are.

The objects shown on the screen are actually further away on the slope.

For example, if the screen displays an object at **D**, the actual distance of the object is at **E**.

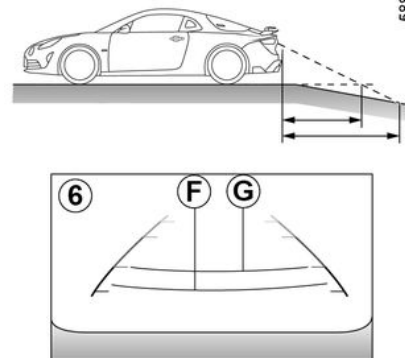

Reversing towards a steep downhill slope

The fixed guidelines **6** show the distances as further than they actually are.

Therefore, the objects shown on the screen are actually closer on the slope.

For example, if the screen displays an object at **G**, the actual distance of the object is at **F**.

PARKING AIDS

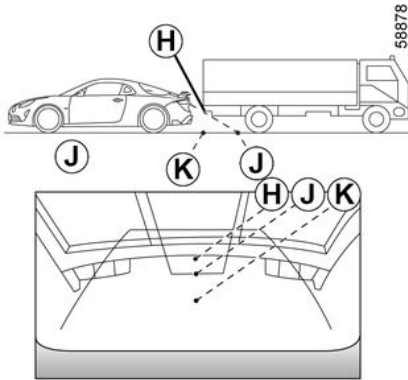

Reversing towards a protruding object

Position **H** seems further than position **J** on the screen. However, position **H** is at the same distance as position **K**.

The trajectory indicated by the fixed and mobile guidelines do not take into account the height of the object. So there is a risk that the vehicle may collide with the object when reversing towards position **K**.

AIR VENTS, HEATING AND AIR CONDITIONING

Air vents: air outlets

Air outlets

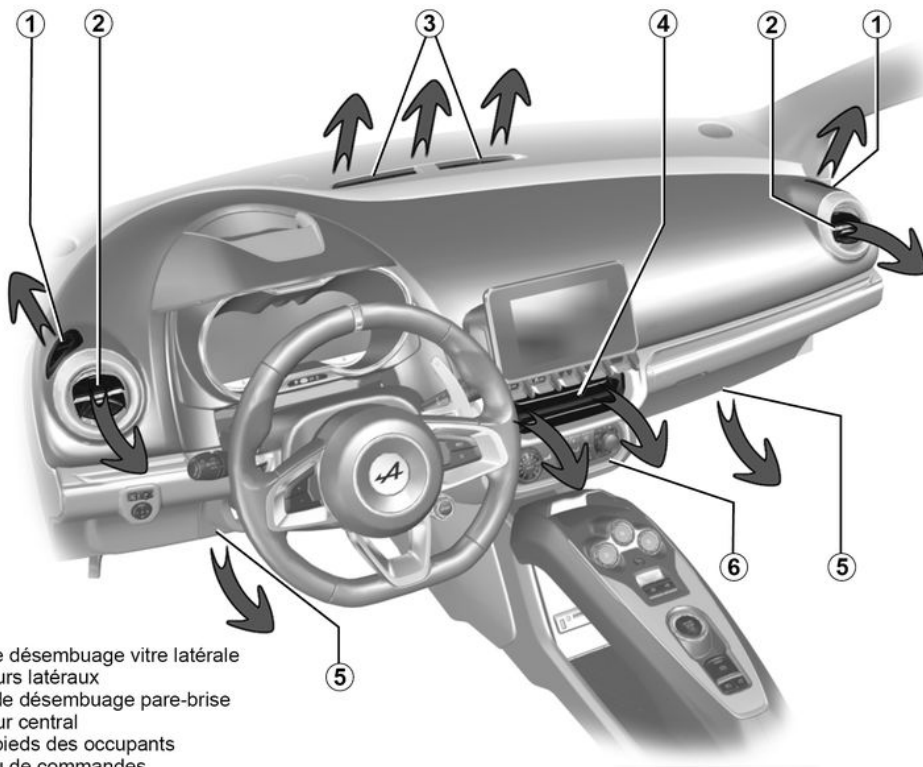

- 1 frise de désembuage vitre latérale
- 2 aérateurs latéraux
- 3 frises de désembuage pare-brise
- 4 aérateur central
- 5 sortie pieds des occupants
- 6 tableau de commandes

42679

AIR VENTS, HEATING AND AIR CONDITIONING

Centre air vent

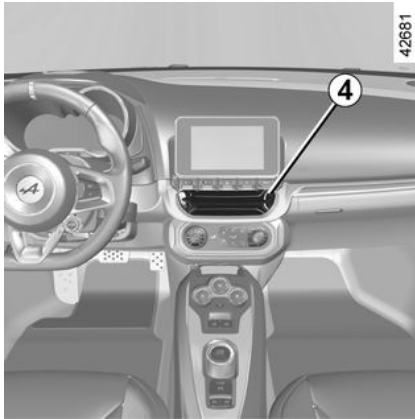

The centre air vent **4** cannot be adjusted.

Side air vents

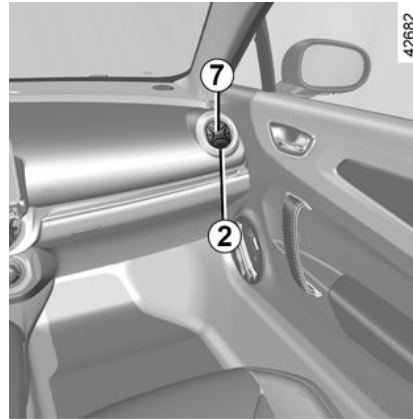

Air flow

To open the air vent **2**, press on the air vent (point **7**) until it is open as far as required.

Direction

To direct the air flow, swivel the side air vent **2**.

To remove bad odours from your vehicles, only use the systems designed for this purpose. Consult an approved dealer.



Do not add anything to the vehicle's ventilation circuit (for example, to remove bad odours).

There is a risk of damage or of fire.

3

Automatic climate control

The controls

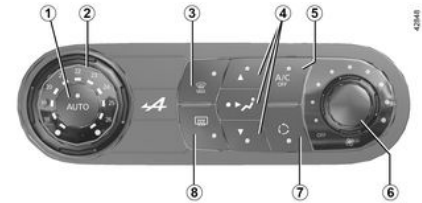

(depending on the vehicle)

1. Automatic mode.
2. Adjusting the air temperature.
3. "Clear View" function.
4. Passenger compartment air distribution adjustment.
5. Air conditioning control.
6. Adjusting the ventilation fan speed.
7. Air recirculation.
8. De-icing the rear view mirrors and, depending on the vehicle, the rear

AIR VENTS, HEATING AND AIR CONDITIONING

screen.

Automatic mode

The automatic climate control system guarantees comfort in the passenger compartment and good visibility (except in the event of extreme conditions), whilst optimising consumption. The system controls the ventilation speed, air distribution, air recirculation, and starting and stopping the air conditioning and air temperature.

AUTO : allows the selected comfort level to be best attained, depending on the exterior conditions. Press the button **1**.

Varying the ventilation speed

In automatic mode, the system uses the most suitable amount of air to reach and maintain the desired comfort level.

You can still adjust the ventilation speed by turning control **6** to increase or reduce the ventilation speed.

Adjusting the air temperature

Turn control **2** to obtain the desired temperature.

Turning the control to the right increases the temperature.

"Clear View" function

Press the button **3** and the indicator lights on buttons **3** and **8** light up.

This function quickly de-ices and demists the windscreen, the front side windows, the exterior rear view mirrors and (depending on the vehicle) the rear screen. It automatically activates the air conditioning.

To exit this function, press button **3** or **1**.



Some buttons have an operating light indicating their operative state.

Adjusting the distribution of air in the passenger compartment

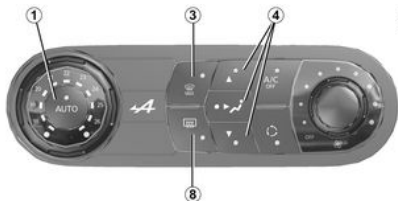

Press one of the buttons **4**. The integrated warning light in the button comes on.

It is possible to combine two positions simultaneously: press two of the buttons **4**.



The air flow is distributed between all the air vents, the front side window demisting air vents and the windscreen demisting vents.



The air flow is mainly directed to the dashboard air vents.



The air flow is directed mainly towards the footwells.

De-icing function



Press button **8** and the built-in warning light comes on. This function quickly de-ices the rear view mirrors and (depending on the vehicle) the rear screen.

To exit this function, press button **8** again. By default, de-icing stops automatically.

AIR VENTS, HEATING AND AIR CONDITIONING

Switching the air conditioning on or off

In automatic mode, the system switches the air conditioning system on or off, depending on the climate conditions.

Press the button **5** to switch off the air conditioning; the integrated indicator light comes on.

Air recirculation (isolation of the passenger compartment)



This function is managed automatically but you can also activate it manually. In this case, the operation is confirmed by the illumination of an indicator light on the button **7**.

The system determines whether or not the air recycling function is used, based on the quality of the outside air.



Demisting/de-icing will still take priority over the air recirculation.

Manual use

Press button **7** and the built-in warning light comes on.

Prolonged use of this position may lead to odours, caused by non-renewal of air, and the formation of condensation on the windows.

We therefore advise you to return to automatic mode as soon as air recirculation is no longer needed, by pressing button **7**.

To exit this function, press the button **7** again.

Stopping the system

Turn the control **6** to "OFF" to stop the system. To start it, turn the control **6** again to adjust the blower speed or press button **1**.

Air conditioning: information and advice on use

Advice on use

In some situations (air conditioning off, air recirculation activated, ventilation speed at zero or low etc.), you may

notice that condensation starts to form on the windows and windscreen.

If there is condensation, use the **"Clear View"** function to remove it, then use the air conditioning in automatic mode to stop it forming again.



Do not add anything to the vehicle's ventilation circuit (for example, to remove bad odours).

There is a risk of damage or of fire.

Maintenance

Refer to the maintenance document for your vehicle for the inspection frequency.



Use the air conditioning system regularly, even in cold weather, running it at least once a month for approximately 5 minutes.

Fuel consumption

You will normally notice an increase in fuel consumption (especially when

AIR VENTS, HEATING AND AIR CONDITIONING

driving in town) when the air conditioning is operating.

For vehicles fitted with air conditioning with no automatic mode, switch off the system when it is not required.

Advice for reducing consumption and helping to preserve the environment

Drive with the air vents open and the windows closed.

If the vehicle has been parked in the sun, open the doors for a few moments to let the hot air escape before starting the engine.

Operating faults

As a general rule, contact your approved dealer in the event of an operating fault.

– Reduction in de-icing, demisting or air conditioning performance.

This may be caused by the cabin filter cartridge becoming clogged.

– No cold air is being produced.

Check that the controls are set correctly and that the fuses are sound. Otherwise, switch off the system.

Presence of water under the vehicle

After prolonged use of the air conditioning system, it is normal for

water to be present under the vehicle. This is caused by condensation.

Refrigerant fluid

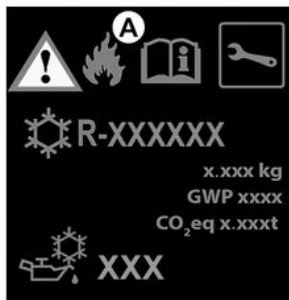

The refrigerant fluid circuit (of which some components are hermetically sealed) may contain fluorinated greenhouse gases.

Depending on the vehicle, you will find the following information on label **A** affixed inside the engine compartment.

The presence and location of the information on label **A** depends on the vehicle.



Type of refrigerant fluid



Type of oil in the air conditioning circuit



Inflammable product



Consult the vehicle user manual



Maintenance

- (1) 0.535 kg Quantity of refrigerant fluid present in the vehicle.
- (2) GWP 4 Global warming potential.
- (3) CO₂ eq 0.002t Quantity in weight and in CO₂ equivalent.

Additional information

Depending on label and depending on the type of refrigerant:

Refrigerant fluid R-1234yf

- (1) 0.535 kg
- (2) GWP 4
- (3) 0.002t



Do not open the refrigerant circuit. The fluid may damage eyes or skin.

59952

AIR VENTS, HEATING AND AIR CONDITIONING



Before performing any action in the engine compartment, the ignition must be switched off (please see the information on "Starting, stopping the engine" in Section 2).

MULTIMEDIA EQUIPMENT

Multimedia sockets 2

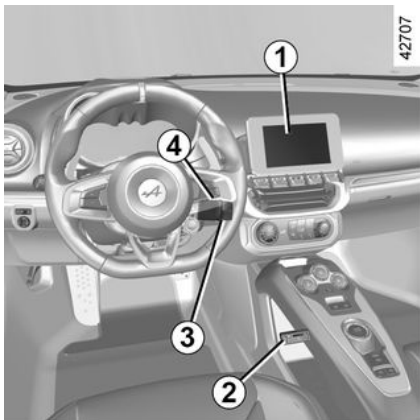

You can use the USB ports to access the multimedia content of your accessories and to update the system. The various sources can be selected using the multimedia screen or the radio and the steering column controls.



The USB ports can also be used to recharge accessories which have been approved by our Technical Department, with a maximum power rating of 12 Watts (5 Volts) per socket.

The Jack socket enables the radio to be used with an auxiliary cable.



Connect accessories with a maximum power of 12 watts only.
Fire hazard.

PASSENGER COMPARTMENT EQUIPMENT

Electric windows

Electric windows



Briefly press or pull on switch **1** or **2** as far as it will go: the window will fully open or close. Pressing the switch again stops the window moving.

From the driver's seat, use switch:

- 1.** for the driver's side;
- 2.** for the passenger side.



Driver's responsibility

Never leave your vehicle with the card inside, with a child, a dependent adult or a pet, even for a short while.

They may pose a risk to themselves or to others by starting the engine or activating equipment (such as the gear lever or electric windows).

If any part of the body becomes trapped, reverse the direction of the window immediately by pressing the relevant switch.

Risk of serious injury.

Impossible to operate the one-touch electric window

The one-touch electric window is equipped with heat protection: if you press the switch for the window more than sixteen consecutive times it goes into protection mode (the window is locked).

You can:

- use the electric window switch briefly and with intervals of approximately 30 seconds;

- with the engine running, the window will be unlocked after approximately 20 minutes of inaction on the electric window switch.

Operating faults

In case of a fault when closing a window, the system reverts to normal mode: pull the switch concerned up as often as necessary to fully close the window (the window will close gradually), hold the switch (still on the closure side) for one second then lower and raise the window fully to reinitialise the system.

If necessary, contact your approved Dealer.



Avoid resting any objects against a half-open window: there is a risk that the electric window could be damaged.

PASSENGER COMPARTMENT EQUIPMENT

Interior lighting

Courtesy light

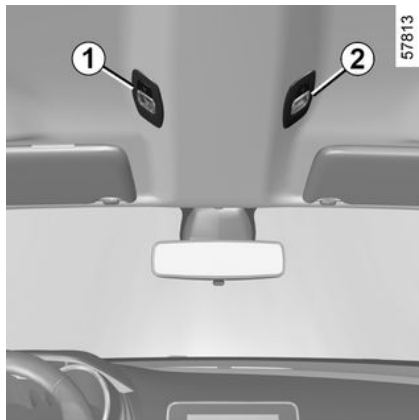

The lights **1** or **2** switch on when one of the doors are opened. The lights only switch off when the doors concerned have been closed correctly after a time delay.

With the doors closed, press the switch to illuminate the light **1** for the driver or the light **2** for the passenger to enable permanent lighting or to switch off the lighting immediately.

Bonnet storage compartment light

3

42692

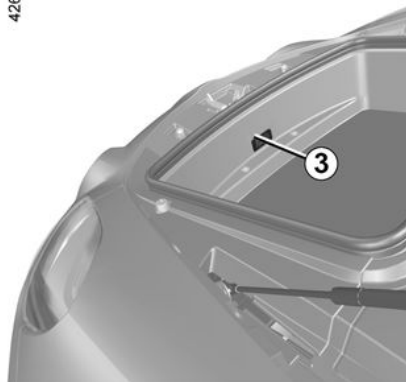

The light **3** switches on when the bonnet is opened.

Light for luggage compartment

42693

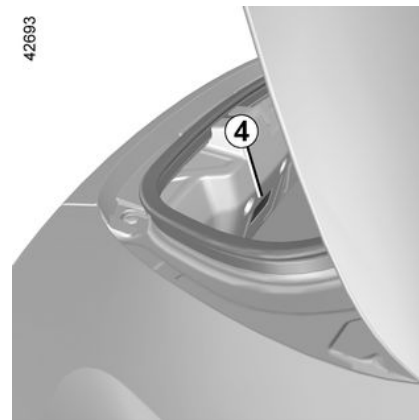

The light **4** comes on when the luggage compartment is opened.



When the doors, rear luggage compartment or bonnet are unlocked and opened the courtesy and door lights switch on temporarily.

PASSENGER COMPARTMENT EQUIPMENT

Accessories socket, ashtray,
cigarette lighter

Accessories socket 1

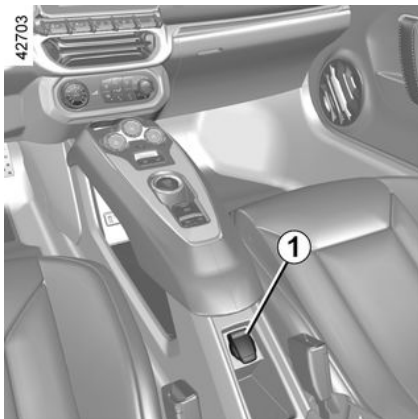

You can use socket **1**. It is provided for connecting accessories approved by our Technical Department.



Connect accessories with a maximum power of 120 watts (12 V) only.

When several accessory sockets are used at the same time, the total power of the connected accessories must not exceed 180 watts.

Fire hazard.

PASSENGER COMPARTMENT STORAGE, FITTINGS

Storage compartment 1

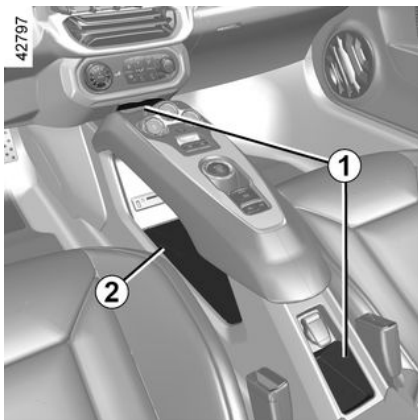

Mobile phone storage compartment 2



Ensure that no hard, heavy or pointed objects are placed in the "open" storage compartments in such a way that they may be projected onto passengers during sudden turning, braking or in the event of an accident.

Cup holders 3

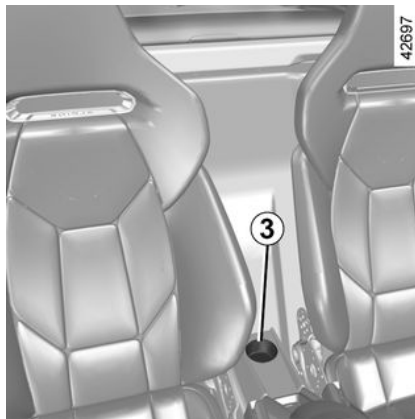

This can be used for storing a mobile ashtray, cup holder, etc.



When turning corners, accelerating or braking, ensure that the receptacle being held by the cup holder is not dislodged. **There is a risk of injury if hot liquid escapes.**

Storage compartment 4

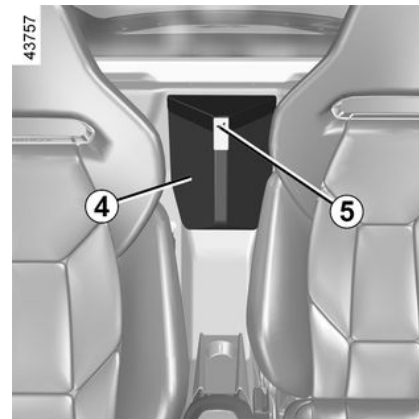

(depending on the vehicle)

To open, lift the cover **5** to access the storage compartment **4**. It can accommodate a bottle of water etc.



Maximum permitted load in the storage compartment **4**: 2 kg evenly distributed.

PASSENGER COMPARTMENT STORAGE, FITTINGS



Whilst driving, ensure that the storage compartment cover **4** is closed.

Risk of injury.

Storage net **6**

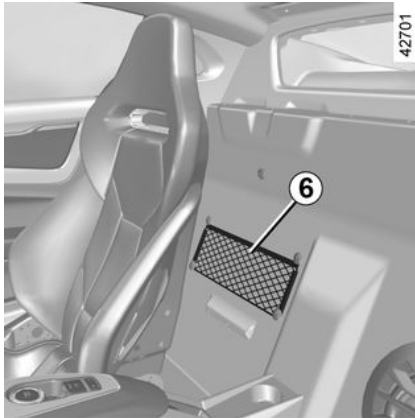

(depending on the vehicle)



Nothing should be placed on the floor (area in front of the driver) as these objects may slide under the pedals during sudden braking manoeuvres, thus obstructing their use.

There is a risk that the pedals become stuck.

Front sun visor

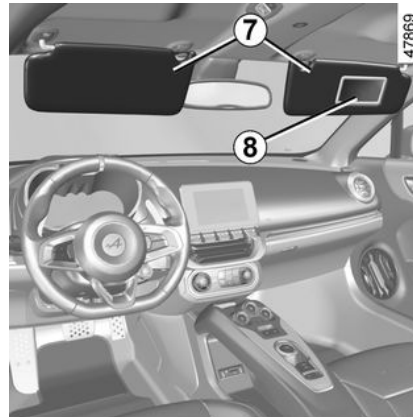

Lower the sun visor **7**.

Courtesy mirror **8**

(depending on the vehicle)

The passenger sun blind is fitted with a courtesy mirror.



Do not place any heavy or hard object outside of the luggage compartment or the fittings provided.

These may pose a risk to the vehicle occupants if the driver has to brake suddenly or if the vehicle is involved in an accident.

Risk of injury.

TRANSPORTING OBJECTS

Storage compartment under the bonnet

Storage compartment A under the bonnet



To access the storage compartment **A**, open the bonnet.

To open and close the bonnet, refer to "Bonnet" in Section 4



Permitted load in the storage compartment: 40 kg evenly distributed.

Vehicles not fitted with storage compartment A



Vehicles not fitted with storage compartment A

Due to the presence of mechanical components:

- it is forbidden to store objects under the bonnet;
- when working on the engine compartment, ensure that you do not leave anything (cloths, tools, etc.) Otherwise, this may lead to the mechanical components being damaged or cause a fire.

Risk of damage or fire;

- When working in the engine compartment, the mechanical components may be hot. The engine cooling fan may also start at any moment.

Risk of injury.



Do not lean on the bonnet: there is a risk that the bonnet may accidentally close.

Luggage compartment

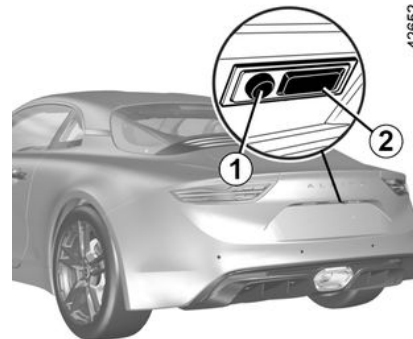

To open

Press the button **2** to open the luggage compartment door. Raise the luggage compartment door to its maximum height to access the luggage compartment.

Note: when the vehicle is locked, press button **1** or **2** to unlock and open the luggage compartment door.

TRANSPORTING OBJECTS

To close

Lower the luggage compartment lid. Press down on the luggage compartment door to fasten it.



Because it is near to the engine compartment, the luggage compartment temperature may exceed

50°C after the engine is switched off.

- Make sure you do not touch the hot sections near the engine compartment. **Risk of burns.**
- Do not expose aerosols or other inflammable products that are sensitive to high temperatures in the luggage compartment. **Risk of fire or explosion.**
- Observe the objects which can be damaged by high temperatures. **Risk of damage.**



The attaching of any carrying device (bike rack, luggage box etc.) resting on the luggage compartment lid is prohibited. To install a carrying device on your vehicle, contact an Approved Dealer.

Luggage compartment storage

TRANSPORTING OBJECTS

Transporting objects in the luggage compartment

3

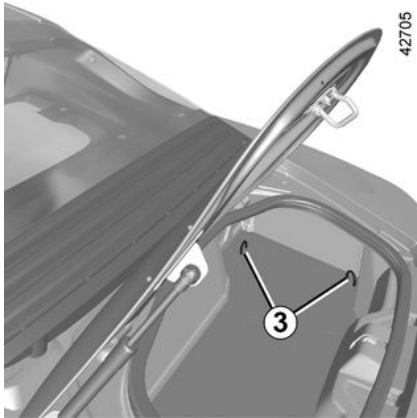

Permitted load in the luggage compartment: 40 kg evenly distributed.



Always position the heaviest items directly on the floor. If the vehicle is equipped, use the lashing points **3** located on the luggage compartment floor.

ACCESSING THE ENGINE, LEVELS

Rear engine compartment

Access to the engine compartment

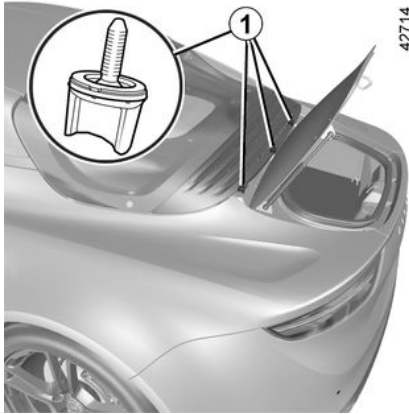

- Open the luggage compartment (refer to "Luggage compartment" in Section 3);
- loosen the tightening bolts **1** of the rear screen **2**;
- raise the rear screen **2**, detach the stay **3** and, for your safety, place it in the housing **5** (movement **A**);
- remove the bolts **6** from the engine cover **4**;
- fit the engine cover **4** carefully on a clean and dry surface.

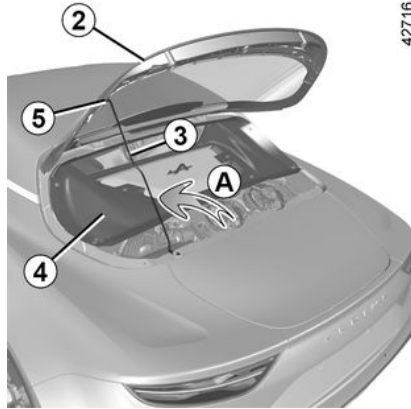

Please note when working close to the engine that it may be hot. Also, the engine cooling fan may start at any

moment. The  label in the engine compartment reminds you of this.

Risk of injury.



As the engine compartment is exposed to high temperatures, it is forbidden to place any object on the engine cover **4**.
Risk of engine damage or fire.

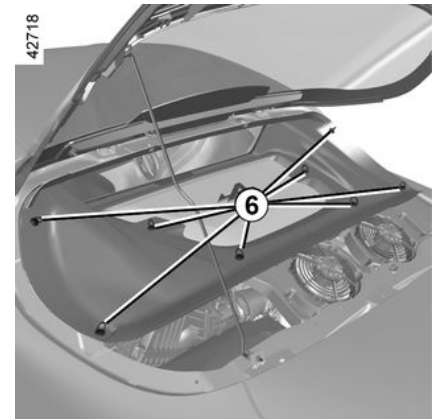

4

ACCESSING THE ENGINE, LEVELS



Before performing any action in the engine compartment, the ignition must be switched off (please see the information on "Starting, stopping the engine" in Section 2).



Deactivate the Stop and Start function for any operation performed in the engine compartment.

Closing/locking of the engine access flap

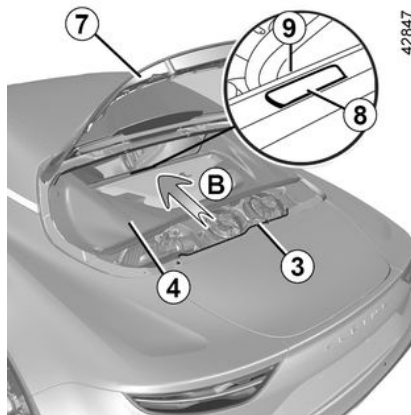

- Check that nothing has been left in the engine compartment;
- position the engine cover **4** (movement **B**) by inserting the component **8** into the housing **9**;
- tighten the bolts **6** of the engine cover;
- remove the stay **3** and store it in its housing;
- hold the rear screen at the end **7** to guide it when closing.

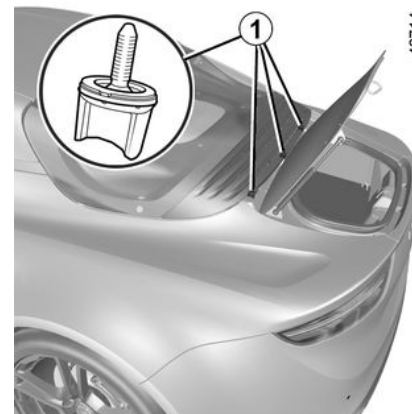

To facilitate complete closing of the rear screen, it is recommended that you keep the luggage compartment open.

Most importantly, do not let go of the rear screen. Guide the rear screen until it is fully closed. Risk of damage to the rear screen.

- Tighten the rear screen bolts **1**;
- Make sure that the rear screen is tightened correctly.

ACCESSING THE ENGINE, LEVELS

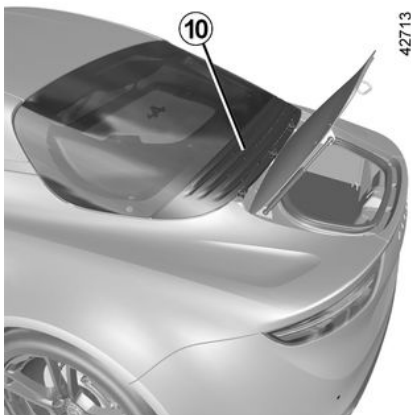

After any procedure in the engine compartment, make sure that you do not forget anything

(cloth, tools, etc.).

Otherwise, this may lead to engine damage or cause a fire.



If carrying out operations near to the air vent **10**, note that this may be hot.

Risk of burns.

Bonnet

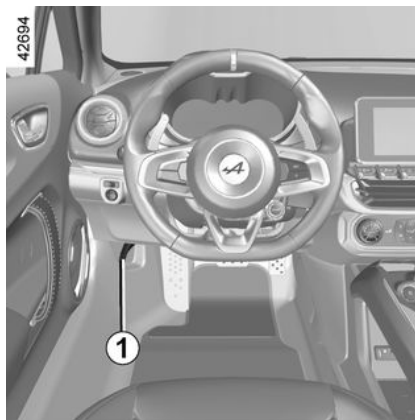

To open, pull the handle **1** located on the left-hand side of the dashboard.

Unlocking the bonnet catch

Push the tab **3** towards the left as you open the bonnet.



Ensure that the bonnet is properly locked. Check that nothing is preventing the catch from locking (gravel, cloth, etc.).

Opening the bonnet

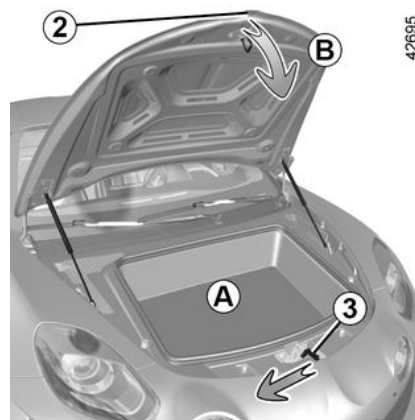

Lift the bonnet, guiding it up. It is held in position by struts.

ACCESSING THE ENGINE, LEVELS

Closing the bonnet

To close the bonnet again, hold the bonnet in the middle and guide it until it is in the closed position (movement **B**). Apply pressure to the bonnet at **2** until it locks.

4



Do not lean on the bonnet: there is a risk that the bonnet may accidentally close.



Vehicles not fitted with storage compartment **A**

Due to the presence of mechanical components:

- it is forbidden to store objects under the bonnet;
- when working on the engine compartment, ensure that you do not leave anything (cloths, tools, etc.) Otherwise, this may lead to the mechanical components being damaged or cause a fire.

Risk of damage or fire;

- When working in the engine compartment, the mechanical components may be hot. The engine cooling fan may also start at any moment.

Risk of injury.



Before carrying out any work under the bonnet, the ignition must be switched off (please see "Starting, stopping the engine" in Section 2).

ACCESSING THE ENGINE, LEVELS

Engine oil

Engine oil level

General information

It is normal for an engine to use oil for lubrication and cooling of moving parts and it is normal to top up the level between oil changes.

However, contact your approved Dealer if more than 0.11 gal (0.5 litre) is being consumed every 600 miles (1,000 km) after the running in period.

Oil change frequency: check the oil level from time to time and certainly before any long journey to avoid the risk of damaging your engine.



Before performing any action in the engine compartment, the ignition must be switched off (please see the information on "Starting, stopping the engine" in Section 2).

Reading the oil level

The oil level should be read with the vehicle on level ground, after the

engine has been switched off for some time.

The dipstick must be used to read the exact oil level and make sure that the maximum level has not been exceeded (risk of engine damage). Refer to the following pages.



Adding engine oil

Use a funnel or protect the filling neck area to avoid engine oil

escaping onto a hot part of the engine compartment or a sensitive part (e.g. electrical components).

Fire hazard.

Minimum oil level warning on the instrument panel

Depending on the vehicle, the instrument panel display only alerts the driver when the oil level is at its minimum.

If the "WARNING: Top Up Engine Oil" message is displayed on the instrument panel, check the oil level on the dipstick. Refer to the following page.



The instrument panel display only gives a warning when the minimum oil level has been reached; to check that the maximum level has not been exceeded, the dipstick must be used.

Minimum oil level check on the instrument panel

With the vehicle positioned on level ground with the ignition off for approximately five minutes, press the engine Start/Stop button without pressing the brake: the "Vehicle Checks in Progress" message appears.

After a few seconds:

- **If the level is correct:** the "OK" message is displayed on the instrument panel;
- **if the level is at the minimum:** the "WARNING: Top Up Engine Oil" message appears on the instrument panel.

It is vital to top up the oil as soon as possible.

ACCESSING THE ENGINE, LEVELS

Reading the level using the dipstick

- Remove the dipstick in the rear engine compartment and wipe it with a clean, lint-free cloth;
- push the dipstick in as far as it will go;
- remove the dipstick again;
- read the level: it should never fall below the "MINI" level **A** nor exceed the "MAXI" level **B**.

Once the level has been read, push the dipstick in as far as it will go.

42833

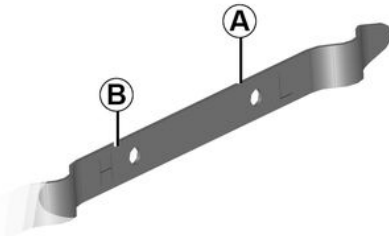

Exceeding the maximum engine oil level

Under no circumstances should the maximum filling level **B** be exceeded: this could damage the engine and the emission control system. If the level exceeds the "MAXI" level, **do not start your vehicle** and contact an authorised dealer.

Topping up, filling, oil change

Topping up/filling

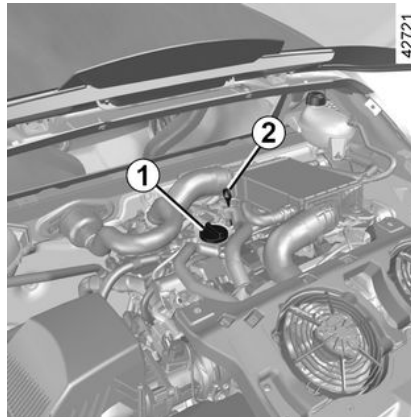

The vehicle must be parked on level ground and the engine should be stopped and cold (for instance, before the engine is started up for the first time in the day).



Before performing any action in the engine compartment, the ignition must be switched off (please see the information on "Starting, stopping the engine" in Section 2).

- Loosen the cap **1**;
- top up the oil (please note that the capacity between the "MINI" and "MAXI" marks on the dipstick **2** is approximately 0.22 gal (1 litre);
- wait for approximately 10 minutes to allow the oil to flow;
- check the level using the dipstick **2** (as described previously).

Once the operation has been completed, ensure that the dipstick is pushed in as far as it will go and that the cap is completely screwed in.

ACCESSING THE ENGINE, LEVELS



Do not exceed the "MAXI" level and remember to refit the cap **1** and the dipstick

2.



Adding engine oil

Use a funnel or protect the filling neck area to avoid engine oil escaping onto a hot part of the engine compartment or a sensitive part (e.g. electrical components).

Fire hazard.

Oil change

Service interval: refer to the maintenance document for your vehicle.

Oil change capacity

Please refer to the maintenance document for your vehicle, or contact an authorised dealer.

Always check the engine oil level using the dipstick, as explained previously (it should never fall below the "MINI" mark nor exceed the "MAXI" mark on the dipstick).



Exceeding the maximum engine oil level

Under no circumstances should the maximum filling level be exceeded: this could damage the engine and the emission control system.
If the oil level exceeds the maximum level, **do not start your vehicle** and contact an approved dealer.

Engine oil grade

Refer to the maintenance document for your vehicle.



Filling and/or checking the oil level:

when topping up or checking the oil level, ensure that

no oil leaks onto the engine components.
Do not forget to properly close the cap and refit the dipstick to prevent any oil spatter on hot engine components.

Fire hazard.



If there is an abnormal or repeated drop in the fluid level, consult an approved dealer.



Please note when working close to the engine that it may be hot. Also, the engine cooling fan may start at any

moment. The  label in the engine compartment reminds you of this.

Risk of injury.



Never run the engine in an enclosed space as exhaust gases are poisonous.

ACCESSING THE ENGINE, LEVELS



Engine oil change: if you are changing the oil when the engine is hot, be careful not to scald yourself as the oil drains.

and "MAXI" marks shown on trays **1** and **2**.

Top this level up **when cold** before it reaches the "MINI" mark.

Frequency of checking coolant level

Check the coolant level regularly (very severe damage is likely to be caused to the engine if it runs out of coolant).

If the level needs to be topped up, only use products approved by our Technical Department which ensure:

- antifreeze protection;
- anti-corrosion protection of the cooling system.



If there is an abnormal or repeated drop in the fluid level, consult an approved dealer.



Before performing any action in the engine compartment, the ignition must be switched off (please see the information on "Starting, stopping the engine" in Section 2).



No operations should be carried out on the cooling circuit when the engine is hot.

Risk of burns.



Please note when working close to the engine that it may be hot. Also, the engine cooling fan may start at any

moment. The  label in the engine compartment reminds you of this.

Risk of injury.

Replacement intervals

Refer to the maintenance document for your vehicle.

4 Coolant level

Coolant level

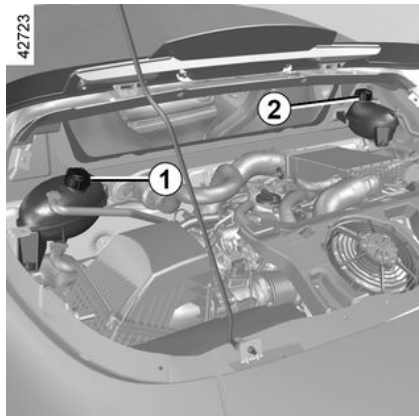

Trays **1** and **2** are located in the rear engine compartment. To access them, refer to the information on the "Rear Engine Compartment" in Section 4.

With the engine off and the vehicle parked on flat ground, the level **when cold** should be between the "MINI"

ACCESSING THE ENGINE, LEVELS

Levels, filters

Brake fluid level

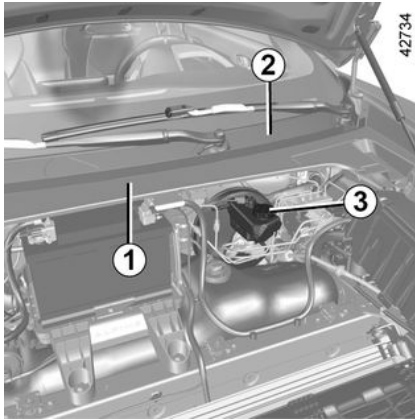

The level should be read with the engine switched off and on level ground.

This should be checked frequently, and immediately if you notice even the slightest loss in braking efficiency.



Before carrying out any work under the bonnet, the ignition must be switched off (please see "Starting, stopping the engine" in Section 2).

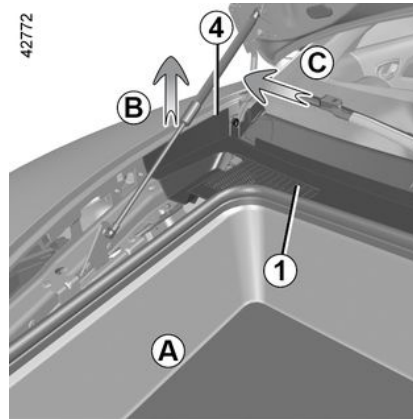

Access

Depending on the vehicle, it may be necessary to remove the scuttle panel grille run channel to access the brake fluid **3**.

To do this:

- hold the rear end of the wing **4** of the scuttle panel grille run channel **1** and pull it upwards to unclip it from the scuttle panel grille **2**;
- take hold of the run channel on the left-hand side then pull it upwards towards you (movement **B**) to unclip it completely;
- move to the left (movement **C**) to release the right-hand side of the run channel and facilitate its movement in relation to the strut;

- place the run channel **1** gently on a clean and dry surface.



Vehicles not fitted with storage compartment **A**

Due to the presence of mechanical components:

- it is forbidden to store objects under the bonnet;
- when working on the engine compartment, ensure that you do not leave anything (cloths, tools, etc.) Otherwise, this may lead to the mechanical components being damaged or cause a fire.

Risk of damage or fire;

- When working in the engine compartment, the mechanical components may be hot. The engine cooling fan may also start at any moment.

Risk of injury.

ACCESSING THE ENGINE, LEVELS

42838

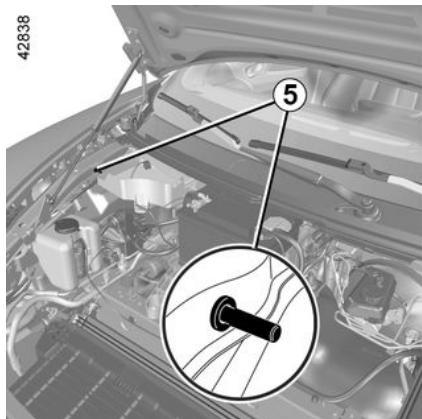

Refitting the scuttle panel grille run channel

It is important to properly reposition the run channel **1**.

To do this:

- position the run channel **1** (movement **D**);
- depending on the vehicle, insert the run channel **1** into the wing cover housing **7** (movement **E**);
- clip on the component **6** on each end of the run channel to the bodywork mounting **5** (movement **F**);
- press the run channel (movement **G**) to clip it in.

42835

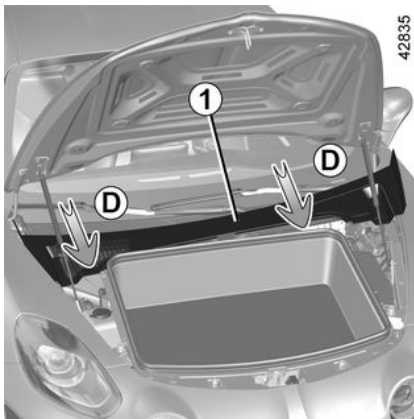

Note: if you have difficulty clipping in the run channel **1** (movement **G**), check if it has been inserted into components **5** and **7** : risk of damage to run channel.

42846

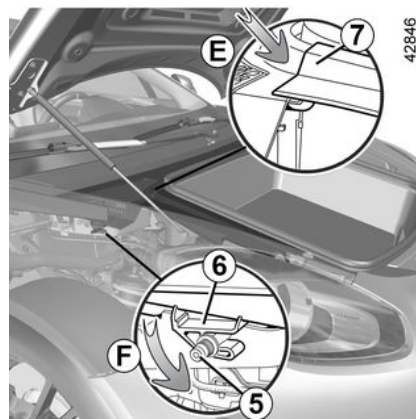

42836

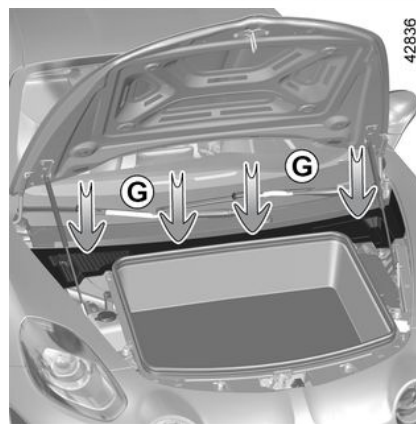

ACCESSING THE ENGINE, LEVELS

Brake fluid (continued)

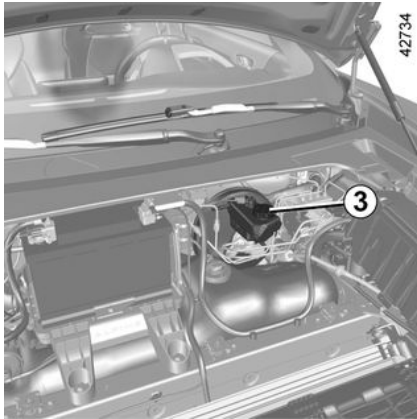

Level 3

It is normal for the level to drop as the brake shoes become worn, but it must never drop lower than the "MINI" warning line.

If you wish to check the disc and trim wear yourself, you should obtain the document explaining the checking procedure from the manufacturer's network or website.

Topping up

After any operation on the hydraulic circuit, a specialist must replace the fluid.

Only use fluids approved by our Technical Department (and taken from a sealed container).

Replacement intervals

Refer to the maintenance document for your vehicle.



If there is an abnormal or repeated drop in the fluid level, consult an approved dealer.

With the engine off, open the cap **8**. Fill until you can see the fluid, then replace the cap.

Note: check the reservoir level regularly and top up the fluid before going on a trip.

Fluid

Windscreen washer fluid. In winter, use anti-freeze product. Use products recommended by an authorised dealer.

Windscreen washer reservoir

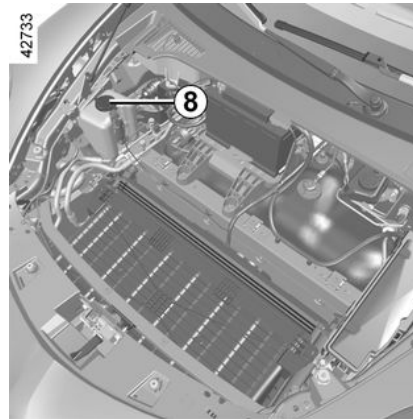

Topping up

ACCESSING THE ENGINE, LEVELS

Filters

The filter elements (air filter, cabin filter etc.) should be replaced during the maintenance operations carried out on your vehicle.

Replacement intervals for filter components: refer to the maintenance document for your vehicle.

4



When working in the engine compartment, ensure that the windscreen wiper stalk is in the off position.

Risk of injury.



Before carrying out any work under the bonnet, the ignition must be switched off (please see "Starting, stopping the engine" in Section 2).

BATTERY

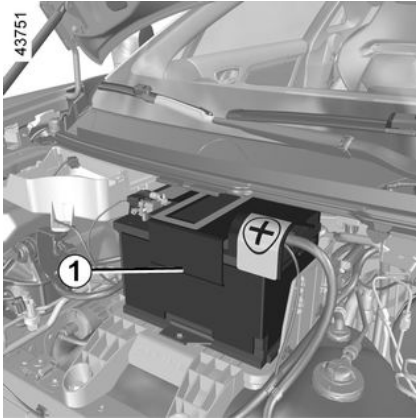

The battery **1** does not require maintenance. **You should not open it or add any fluid.**



Handle the battery with care as it contains sulphuric acid which must not come into contact with the eyes or skin. If it does, wash the affected area with plenty of cold water. If necessary, consult a doctor.
Keep any flames, red hot objects or sparks away from the battery components (risk of explosion).



For your own safety and for the proper operation of the vehicle's electrical equipment (lights, windscreen wipers, ABS, etc.), any intervention on the battery (removal, disconnection, etc.) must categorically be performed by a specialist professional. Risk of serious burns or electric shocks.

You must respect the replacement intervals (without exceeding them) as stated in the maintenance document.

The battery is a specific type. Please ensure it is replaced with the same type. Call an approved Dealer.

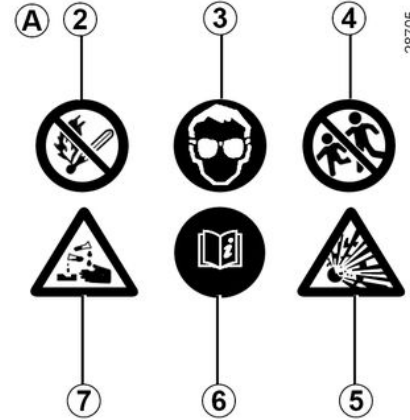

Label A

Observe the indications on the battery:

- **2** naked flames and smoking are prohibited;
- **3** eye protection compulsory;
- **4** keep away from children;
- **5** explosive material;
- **6** refer to the manual;
- **7** corrosive materials.

BATTERY



Before carrying out any work under the bonnet, the ignition must be switched off (please see "Starting, stopping the engine" in Section 2).

4

AERODYNAMIC EQUIPMENT

Front blade 1 and rear spoiler 2

57840

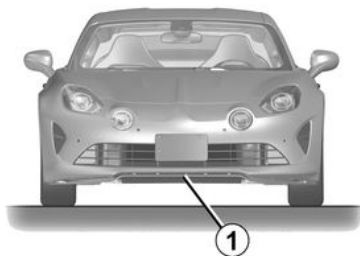

57839



4

The front blade **1** and the rear spoiler **2** ensure the stability of the vehicle at high speeds.

In the event of damage, reduce your speed and consult your authorised dealer as soon as possible.



Never interfere with the front blade or the rear spoiler.

In the event of an impact to the underside of the vehicle (e.g. striking a post, raised kerb or other street furniture) or on the rear spoiler, have your vehicle checked by an authorised dealer. Never use a roller-type car wash. Please refer to the paragraph on "Bodywork maintenance" in Section 4.

Risk of injury and/or damage to the vehicle.

CLEANING

Bodywork maintenance

You should do the following

Wash your car frequently, **with the engine off**, with cleaning products recommended by the manufacturer (never use abrasive products). Rinse thoroughly beforehand using a jet washer:

- spots of tree resin and industrial pollution;
- mud in the wheel arches and underneath the body which forms damp patches;
- **bird droppings, which cause a chemical reaction with the paint that rapidly discolours paintwork and may even cause the paint to peel off;**

wash the vehicle **immediately** to remove these marks as it is impossible to remove them by polishing;

- salt, particularly in the wheel arches and underneath the body after driving in areas where the roads have been gritted.

Remove any plant matter (resin, leaves, etc.) from the vehicle regularly.

Observe local regulations about washing vehicles (e.g. do not wash your vehicle on a public highway).

Observe the vehicle stopping distances when driving on gravelled surfaces to prevent paint damage.

Repair, or have repaired quickly, areas where the paint has been damaged, to prevent corrosion spreading.

Remember to visit the body shop periodically in order to maintain your anti-corrosion warranty. Refer to the maintenance document.

If mechanical components, hinges, etc. have been cleaned, they must be protected again by spraying with products approved by our Technical Department.



We have selected special products to care for your vehicle and you can obtain these from the manufacturer's accessory outlets.

Do not do the following



Wash the vehicle in bright sunlight or freezing temperatures.

Do not scrape off mud or dirt without pre-wetting.

Allow dirt to accumulate on the exterior.

Allow rust to form following minor impacts.

Do not use solvents not approved by our Technical Department to remove stains as this could damage the paintwork.

Do not drive in snow or muddy conditions without washing the vehicle, particularly under the wheel arches and body.

Degrease or clean using high-pressure cleaning equipment or by spraying products not approved by our Technical Department:

Doing this could give rise to corrosion or operational faults.

Vehicles with a matte paint finish

This type of paint requires certain precautions.

You should do the following

Wash the vehicle by hand using plenty of water, using a soft cloth or a gentle sponge.

Do not do the following



CLEANING

Use wax-based products (polishing).

Rub too hard.

Wash the vehicle in a roller-type car wash.

Attach stickers to the paintwork (risk of leaving marks).

Wash the vehicle using a high-pressure cleaning device.

Using a roller type car wash

Return the windscreen wiper stalk to the Park position (refer to the information on the "Windscreen washer, wiper" in Section 1). Check the mounting of external accessories, additional lights and rear view mirrors, and ensure that the wiper blades are secured with adhesive tape.

Remove the radio aerial mast if your vehicle is fitted with this equipment.

Remember to remove the tape and refit the antenna after washing.

Special features of vehicles with aerodynamic equipment



Never use a roller-type car wash on vehicles fitted with a rear spoiler.
Risk of damage to the

vehicle.

Cleaning the headlights, sensors and cameras

Use a soft cloth or cotton wool. If this does not clean them properly, moisten the cloth with soapy water, then wipe clean with a soft damp cloth or cotton wool. Finally, carefully dry off with a soft dry cloth.

Do not use alcohol-based cleaning products or utensils such as scrapers.

Cleaning stickers, decorative films, etc.

You should do the following

Use a soft cloth or cotton wool. Moisten it with soapy water, then always wipe clean with a soft cloth or cotton wool.

Finally, carefully dry off with a soft dry cloth.

Do not do the following



Use alcohol-based cleaning products. Use utensils (e.g. a scraper). Rub too hard.

Wash the area using a high-pressure cleaning device.

Interior trim maintenance

Multimedia screen

Maintenance of the screen may depend on the type of multimedia equipment. Please refer to the multimedia instructions for further information.

Glass instrument panel

(e.g. instrument panel, clock, exterior temperature display, etc.)

Use a soft cloth or cotton wool.

If this does not clean them properly, use a soft cloth (or cotton wool) slightly moistened with soapy water and then wipe clean with another soft damp cloth or cotton wool.

Finally, **carefully** dry off with a soft dry cloth.

Do not use products containing alcohol and/or spray fluids on the area.

Seat belts

They must remain clean.

Use products selected by our Technical Department (approved outlets) or warm, soapy water and a sponge and wipe with a dry cloth.

Detergents or dyes must not be used under any circumstances.

CLEANING

Textiles (seats, door trim, etc)

Vacuum-clean the textiles **regularly**.

Liquid stain

Use soapy water.

Dab lightly (never rub) with a soft cloth, rinse and remove the excess.

Solid or pasty stain

Carefully remove the excess solid or pasty material **immediately** using a spatula (working from the edges to the centre to avoid spreading the stain).

In the case of a liquid stain, clean as indicated.

Special instructions for sweets or chewing gum

Fit an ice cube on the stain to solidify it, then proceed as for a solid stain.



For further recommendations for maintaining the interior, and/or for any unsatisfactory results, please see an authorised dealer.

Removal/replacing removable equipment originally fitted in the vehicle

If you need to remove equipment in order to clean the passenger compartment (for example, mats), always ensure that they are correctly refitted and are the right way around (the driver's mat should be fitted on the driver's side, etc.) and fit them with the components supplied with the equipment (for example, the driver mat should always be fixed using the pre-fitted mounting components).

With the vehicle stationary, always ensure that nothing will impede driving (anything obstructing the pedals, heel wedged by the mat etc.).

Do not do the following



Position objects such as deodorants, scents etc. near air vents as this could damage your dashboard trim.

Use high-pressure cleaning equipment or sprays inside the passenger compartment:

without careful use, this equipment could impair the correct functioning of the electrical or electronic components

in the vehicle, or have other detrimental effects.

TYRES

Tyres

Tyre and wheel safety

The tyres are the only contact between the vehicle and the road, so it is essential to keep them in good condition.

You must make sure that your tyres conform to local road traffic regulations.

Maintaining the tyres



The tyres must be in good condition and the treads must have sufficient depth: tyres approved by our Technical Department include wear warning strips **1** which are **indicators**

moulded into the tread at several points.

When the tyre tread has been worn to the level of the wear indicators, **they become visible 2 : it is necessary to replace your tyres because the tread rubber is 1.6 mm deep at most, resulting in poor road-holding on wet roads.**

An overloaded vehicle, long journeys by motorway, particularly in very hot weather, or continual driving on poorly surfaced minor roads will lead to more rapid tyre wear and affect safety.



Incidents which occur when driving, such as striking the kerb, may damage the tyres and wheel rims, and could also lead to misalignment of the front or rear axle geometry. In this case, have the condition of these checked by an approved dealer.

Tyre pressures

Adhere to the tyre pressures (including the emergency spare wheel). The tyre pressures should be checked at least once a month and before using the vehicle on a circuit or before a long

journey (refer to the label attached to the driver's door edge, or, depending on the vehicle, on the bottom of the driver's door).



Incorrect tyre pressures lead to abnormal tyre wear and unusually hot running.

These are factors which may seriously affect safety and lead to:

- poor road holding;
- the risk of blow-outs or of throwing a tread.

The pressure depends on the load and the speed of use. Adjust the pressures according to the conditions of use (refer to the label affixed to the edge of the driver's door, or, depending on the vehicle, on the bottom of the driver's door).

Pressures should be checked when the tyres are cold. Ignore higher pressures which may be reached in hot weather or after driving at high speed.

TYRES

If tyre pressures cannot be checked when the tyres are **cold**, assume an **increase of 0.2 to 0.3 bar** (or 3 PSI).

Never deflate a hot tyre.



Please be aware that a poorly tightened or missing valve cap can make the tyres less airtight and may lead to pressure loss.

Always use valve caps identical to the originals and screw them down fully.

Vehicle fitted with a tyre pressure monitoring system

If the tyres are under-inflated (puncture, low pressure, etc.), the



warning light appears on the instrument panel: refer to the information on "Tyre pressure monitoring system" in Section 2.

Emergency spare wheel

Refer to the information on the "Emergency spare wheel" and "Changing a wheel" in Section 5.

Exchanging the right-hand and left-hand wheels

This practice is not recommended.



The front and rear wheels have different dimensions. For safety reasons, it is not permitted to exchange the front wheels (tyres and/or rims) with the rear wheels.

Fitting new tyres



For your safety reasons. Only tyres identical to those fitted originally or recommended by an approved dealer must be used. Failure to follow these instructions could endanger your safety. This could adversely affect stability, behaviour, braking or the clearance between the bodywork and the tyres.

Some of these effects could lead to the loss of control of the vehicle under certain driving conditions.

TYRES



For your safety and to comply with the law.

When they need to be replaced, only tyres of the same make, size, type and profile should be used on a single axle.

They must have a load capacity and speed rating at least equal to those of the original tyres and correspond to the tyres recommended by an approved Dealer.

Failure to heed these instructions could endanger your safety and affect your vehicle's roadworthiness.

Risk of loss of control of the vehicle.

TYRES

Use in winter

Chains

For safety reasons, the fitting of snow chains to the rear axle is a requirement. It is strongly recommended that they also be fitted to the front axle.

Chains cannot be fitted to tyres which are larger than those originally fitted to the vehicle.



If you wish to fit snow chains, you must use **special equipment**. Consult an approved

dealer.

"Snow" or "Winter" tyres

We would recommend that these be fitted to all **four wheels** to ensure that your vehicle retains maximum adhesion.

Caution: these tyres sometimes have a specific direction of rotation and a maximum speed index which may be lower than the maximum speed for your vehicle.

Studded tyres

This type of equipment may only be used for a limited period and as laid down by local legislation. It is necessary to observe the speed specified by current legislation.

These tyres must, at a minimum, be fitted to the two rear wheels.



In all cases, we would recommend that you contact an approved Dealer who will be able to advise you on the choice of equipment which is most suitable for your vehicle.

TYRES

Tyre pressure

Label A

47900



Open the driver's door to read it. Label **A** is located on the edge of the door, or depending on the vehicle, at the bottom of the door.

Tyre pressures should be checked when the tyres are cold.

If tyre pressures cannot be checked when the tyres are **cold, assume an increase of 0.2 to 0.3 bar (or 3 PSI)**. **Never deflate a hot tyre.**

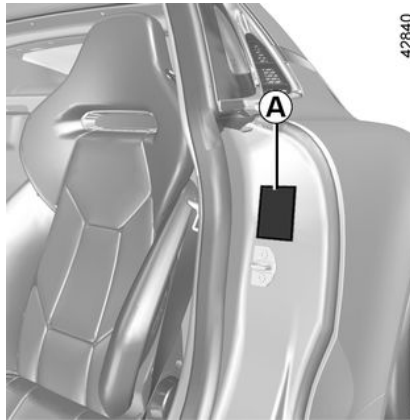

Vehicle fitted with a tyre pressure monitoring system

If the tyres are under-inflated (puncture, low pressure, etc.), the



warning light appears on the instrument panel: refer to the information on "Tyre pressure monitoring system" in Section 2.

42843

A	A diagram of a car from a top-down perspective. A horizontal line with an arrow at the left end points from the driver's side door area towards the left edge of the table.	
	B	B
C	An icon of a road with a truck, representing driving speed on roads and motorways.	G
D	ECO	G
E	An icon of a road with a car, representing driving speed on a circuit.	G
	F	G

B. : dimension of the tyres fitted to the vehicle.

C. : driving speed intended on roads and motorways.

D. : recommended pressure for optimising fuel consumption.

Note: driving comfort may be altered.

E. : driving speed intended on a circuit.

F. : front tyre pressure.

G. : rear tyre pressure.

Tyre safety and the use of chains: please refer to the "Tyres" paragraph in Section 5 for information on servicing conditions and, depending on the version, the use of chains.

TYRES



For your safety and to comply with the law. When they need to be replaced, only tyres of the same make, size, type and profile should be used on a single axle.

They must either have a load capacity and speed rating at least equal to those of the original tyres, or conform to those recommended by an authorised dealer.

Failure to heed these instructions could endanger your safety and affect your vehicle's roadworthiness.

Risk of loss of control of the vehicle.

Tyre inflation kit

32788



The kit repairs tyres when the tread **A** has been damaged by objects smaller than 4 mm. It cannot repair all types of puncture, such as cuts larger than 4 mm, cuts in the tyre sidewall **B**, etc.

Ensure also that the wheel rim is in good condition.

Do not pull out the foreign body causing the puncture if it is still in the tyre.



Do not attempt to use the inflation kit if the tyre has been damaged as a result of driving with a

puncture.

You should therefore carefully check the condition of the tyre sidewalls before any operation. Driving with underinflated, flat or punctured tyres can be dangerous and may make the tyre impossible to repair.

This repair is temporary.

A tyre which has been punctured should always be inspected (and repaired, where possible) by a specialist as soon as possible.

When taking a tyre which has been repaired using this kit to be replaced, you must inform the specialist.

When driving, vibration may be felt due to the presence of the repair product injected into the tyre.

TYRES



The kit is only approved for inflating the tyres of the vehicle originally equipped with the kit.

It must never be used to inflate the tyres of another vehicle, or any other inflatable object (rubber ring, rubber boat, etc.).

Avoid spillage on skin when handling the repair product bottle. If droplets do leak out, rinse them off with plenty of water.

Keep the repair kit away from children.

Do not dispose of the empty bottle in the countryside. Return it to your approved dealer or to a recycling organisation.

The bottle has a limited service life which is indicated on its label.

Check the expiry date.

Contact an approved dealer to replace the inflation tube and repair product bottle.

35749

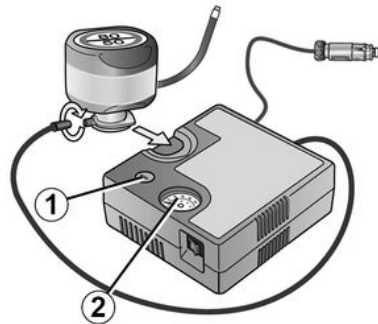

Before using the kit, park the vehicle at a sufficient distance from traffic, switch on the hazard warning lights, apply the parking brake, ask all passengers to leave the vehicle and keep them away from traffic.

In the event of a puncture, use the kit located in the luggage compartment.

Vehicle fitted with a tyre pressure monitoring system

If the tyres are under-inflated (puncture, low pressure, etc.), the



warning light appears on the instrument panel: refer to the information on "Tyre pressure monitoring system" in Section 2.

With the engine running and the parking brake applied,

- disconnect any accessories from the vehicle's accessories sockets;
- **see the information on the inflation kit compressor** located in the vehicle luggage compartment and follow the instructions for use;
- inflate the tyre to the recommended pressure (please refer to the information on "Tyre pressure");
- after a maximum of **15 minutes**, stop inflating and read the pressure (on the pressure gauge **1**).

Note: while the container is emptying (approximately 30 seconds), the pressure gauge 1 will briefly indicate a pressure of up to 6 bar, then the pressure drops;

- adjust the pressure: to increase it, continue inflation with the kit. To reduce it, press the button **2**.

TYRES



If the vehicle is parked on the hard shoulder, you must warn other road users of your vehicle's presence with a warning triangle or with other devices as per the legislation applying to the country you are in.



Nothing should be placed around the driver's feet as during sudden braking such objects may slide under the pedals and obstruct their use.

depending on the vehicle, on the base of driver's door) and readjust it. Otherwise, contact an approved dealer: the tyre cannot be repaired.

Precautions when using the kit

The kit should not be operated for more than 15 consecutive minutes.

The container must be replaced after the first use even if liquid remains inside.



Following repair with the kit, do not travel further than 124 miles (200 km).

In addition, reduce your speed and under no circumstances exceed 50 mph (80 km/h). The sticker, which you must affix in a prominent position on the dashboard, reminds you of this.

Depending on the country or local legislation, a tyre repaired with the inflation kit will need to be replaced.

35749

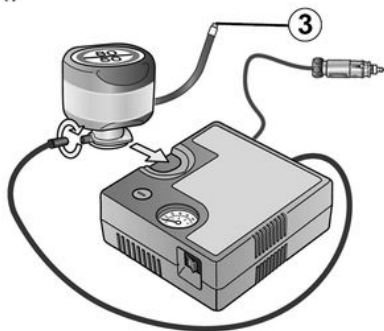

If the recommended pressure of 1.8 bar cannot be achieved after 15 minutes, repair is impossible. Do not drive the vehicle. Consult an authorised dealer.

Once the tyre is correctly inflated, remove the kit: unscrew the inflation adapter slowly from the container **3** to prevent any product spatter and store the container in plastic packaging to prevent product leaks.

- Affix the driving recommendation label (located under the container) to the dashboard where the driver can see it.
- Put the kit away.
- At the end of this initial inflation operation, air will still escape from the tyre. You must drive a short distance in order to seal the hole.
- Start the vehicle immediately and drive at a speed of 12 to 37 mph (20 to 60 km/h) in order to distribute the product evenly in the tyre. After driving a distance of 2 miles (3 km), stop the vehicle and check the tyre pressure.
- If the pressure is greater than 1.3 bar but less than the recommended pressure (refer to the label affixed to the edge of the driver's door or,

TYRES



Please be aware that a poorly tightened or missing valve cap can make the tyres less airtight and may lead to pressure loss.
Always use valve caps identical to the originals and screw them down fully.

Tools

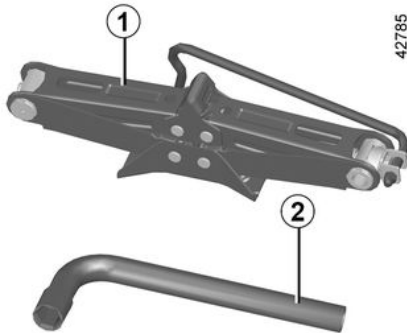

The presence of the tools depends on the vehicle.

The emergency spare wheel storage case located on the passenger seat

contains a bag containing the following tools:

Jack 1

Fold it correctly before refitting it in its casing (ensure that the wheelbrace is correctly positioned).

Wheelbrace 2

This can be used to lock or unlock the wheel bolts and the towing eye 4.

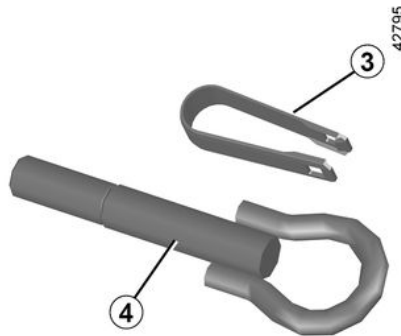

The inflation kit case located in the luggage compartment contains the following tools:

Tweezers 3

This is used to remove the wheel bolt covers.

Towing eye 4

Please refer to the information on "Towing: breakdown recovery" in Section 5.

Fuse tweezers 5

Pack of fuses

Please see the information on "Fuses" in Section 5.

42986



TYRES



Do not leave the tools unsecured inside the vehicle as they may be projected during braking.

After use, check that all the tools are correctly fitted into the case, then place the case correctly in its storage compartment **to avoid any risk of injury**.

The jack is designed for wheel changing purposes only. Under no circumstances should it be used for carrying out repairs underneath the vehicle or to gain access to the underside of the vehicle.

Puncture, emergency spare wheel

In case of puncture

Depending on the vehicle, a tyre inflation kit or emergency spare wheel is provided (refer to the following pages).

Vehicle fitted with a tyre pressure monitoring system

If the tyres are under-inflated (puncture, low pressure, etc.), the



warning light appears on the instrument panel: refer to the information on "Tyre pressure monitoring system" in Section 2.



If the vehicle is parked on the hard shoulder, you must warn other road users of your vehicle's presence with a warning triangle or with other devices as per the legislation applying to the country you are in.

42818

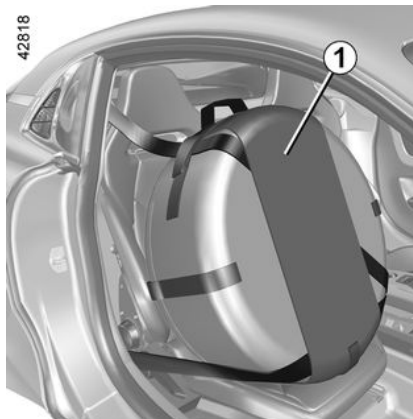

If the spare wheel has been stored for several years, have it checked by your Dealer to ensure that it is safe to use.

- Never fit more than one emergency spare wheel to the same vehicle.
- Using the emergency spare wheel at the rear may reduce the vehicle's ground clearance.
- Replace the emergency spare wheel as soon as possible with a wheel identical to the original one.
- When this is fitted to the vehicle, which must only be a temporary measure, the driving speed must not exceed the speed indicated on the label on the wheel.
- Fitting an emergency spare wheel may alter the way the vehicle usually runs. Avoid sudden acceleration or deceleration and reduce your speed when cornering.

TYRES

– The emergency spare wheel can only be fitted with a device or specific equipment. Consult an approved dealer.

Emergency spare wheel

If the vehicle is equipped with one, the emergency spare wheel **1** is located in a storage case strapped to the passenger seat.

Changing a wheel

Vehicles equipped with a jack and wheel brace

For vehicles equipped with such, remove the wheel bolt covers using the pliers stored in the inflation kit casing.

Unlock the wheel bolts using the wheel brace **1**. Position it so as to be able to push from above.

Crank up the jack **2** by hand to position the jack head against the jacking point closest to the wheel concerned and marked by an arrow **3**.



If the vehicle is not equipped with a jack, wheel wrench or other, a tooling kit can be obtained from an Approved Dealer.

Continue to crank the jack so that the baseplate is correctly positioned (it should be underneath the vehicle and aligned with the jack head).

Turn the wheel brace until the wheel lifts off the ground.



To prevent any risk of injury or damage to the vehicle, only crank the jack until the wheel you are replacing is a maximum of three centimetres off the ground.



If the vehicle is parked on the hard shoulder, you must warn other road users of your vehicle's presence with a warning triangle or with other devices as per the legislation applying to the country you are in.

Undo the bolts and take off the wheel. Fit the emergency spare wheel on the central hub and turn it to locate the mounting holes in the wheel and the hub.

Tighten the bolts, checking that the wheel is correctly positioned on its hub.

Lower the jack.

With the wheel on the ground, tighten the bolts fully and have the tightness of the bolts checked and the emergency spare wheel pressure checked as soon as possible.

TYRES



If you have a puncture, replace the wheel as soon as possible.

A tyre which has been punctured should always be inspected (and repaired, where possible) by a specialist.



Do not leave the tools unsecured inside the vehicle as they may be projected during braking.

After use, check that all the tools are correctly fitted into the case, then place the case correctly in its storage compartment to avoid any risk of injury.

The jack is designed for wheel changing purposes only. Under no circumstances should it be used for carrying out repairs underneath the vehicle or to gain access to the underside of the vehicle.

5

Vehicle fitted with a tyre pressure monitoring system

If the tyres are under-inflated (puncture, low pressure, etc.), the



warning light appears on the instrument panel: refer to the information on "Tyre pressure monitoring system" in Section 2.

BREAKDOWN RECOVERY

Towing: breakdown

Before all towing operations, set the gearbox to N position (refer to "Automatic gearbox" in Section 2), unlock the steering column, then release the parking brake (refer to "Electronic parking brake" in Section 2).

If the gearbox cannot be set to N position, please contact an authorised dealer.

Steering column unlocking

With the "hands-free" card in the passenger compartment, press the engine start button (**without pressing the brake pedal in order not to start the engine**) or, depending on the vehicle, insert the remote control card in the reader (refer to "Starting, stopping the engine" in Section 2).

The steering column unlocks and the accessory functions are powered: you can use the vehicle's lights (direction indicators, brake lights, etc.). At night the vehicle must have its lights on.

Once you have finished towing, lock the vehicle using the card (refer to "Card: general information, use" and "Hands-free card: use" in Section 1) to avoid the risk of the battery discharging.

With the ignition switched off, the gearbox is no longer lubricated. Transport the vehicle on a flatbed lorry.

In exceptional circumstances, you can tow the vehicle with all four wheels on the ground only in a forward gear, with the gearbox in Neutral (N) position, over a maximum distance of 50 miles (80 km) and not exceeding a speed of 16 mph (25 km/h).

The speed specified by current legislation for towing must always be observed.



Leave the "hands-free card" in the vehicle or, depending on the vehicle, do not remove the remote control card from the reader while the vehicle is being towed.

Risk of the steering column locking.

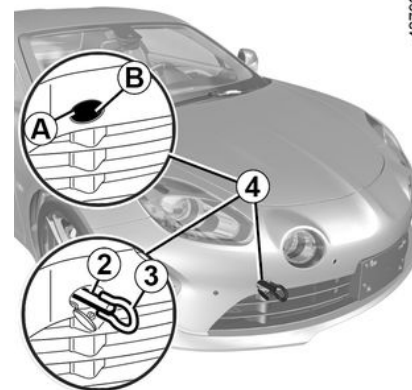

42792

5

Only use the front towing point 2

(never use the drive shafts or any other part of the vehicle).

This towing point may only be used for pulling. It must never be used for lifting the vehicle directly or indirectly.



When the engine is stopped, steering and braking assistance are no longer provided.

Access to the towing point

Press zone **A** and maintain the pressure while pulling on zone **B** to open the flap **4**.

BREAKDOWN RECOVERY

Tighten the towing eye 3 to the maximum: first by hand until it stops, then finish by locking it using the wheelbrace.

Only use the towing eye **3** (refer to the information on "Tools" in Section 5).



Ensure that the towing eye is bolted correctly.
Risk of losing the towed object.



Do not leave the tools unsecured inside the vehicle as they may be projected during braking.



- Use a rigid tow bar.
- a vehicle must not be towed if it is not fit to be driven.
- avoid accelerating or braking suddenly when towing, as this may result in damage being caused to the vehicle.
- In any case, it is advisable not to exceed **16 mph (25 km/h)**.

Battery: breakdown recovery

To avoid all risk of sparks:

- Ensure that the "energy consumers" (ceiling lights, etc.) are switched off before disconnecting or reconnecting a battery.
- When charging, stop the charger before connecting or disconnecting the battery.
- Do not place metal objects on the battery as this could create a short circuit between the terminals.
- Always wait at least one minute after the engine has been switched off before disconnecting a battery.
- Make sure that you reconnect the battery terminals after refitting.



Before carrying out any work under the bonnet, the ignition must be switched off (please see "Starting, stopping the engine" in Section 2).

Connecting a battery charger

The battery charger must be compatible with a battery with nominal voltage of 12 volts.

Do not disconnect the battery while the engine is running. **Follow the instructions given by the manufacturer of the battery charger you are using.**



Special procedures may be required to charge some batteries. Contact your approved dealer.
Avoid all risk of sparks which may cause an immediate explosion, and charge the battery in a well ventilated area.
Risk of serious injury.

BREAKDOWN RECOVERY



Handle the battery with care as it contains sulphuric acid which must not come into contact with the eyes or skin. If it does, wash the affected area with plenty of cold water. If necessary, consult a doctor.

Keep any flames, red hot objects or sparks away from the battery components (risk of explosion). When working in the engine compartment, the mechanical components may be hot.

Risk of injury.

Starting the vehicle using the battery from another vehicle

If you have to use the battery from another vehicle to start, obtain suitable jump leads (with a large cross section) from an approved dealer or, if you already have jump leads, ensure that they are in perfect condition.

The two batteries must have an identical nominal voltage: 12 V. The battery supplying the current should have a capacity (amp-hours, Ah) which is at least the same as that of the discharged battery.

Ensure that there is no risk of contact between the two vehicles (risk of short circuiting when the positive terminals are connected) and that the discharged battery is properly connected. Switch off your vehicle ignition.

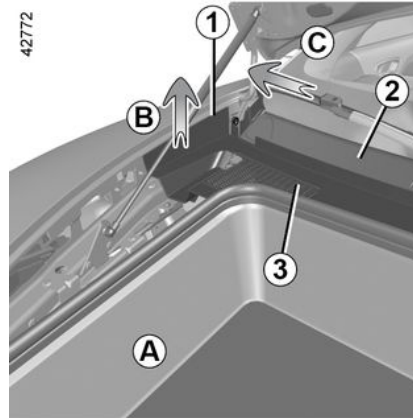

Depending on the vehicle, it may be necessary to remove the scuttle panel grille run channel to access the battery. To do this:

- hold the rear end of the wing **1** of the scuttle panel grille run channel **3** and pull it upwards to unclip it from the scuttle panel grille **2**;
- take hold of the run channel on the left-hand side then pull it upwards

towards you (movement **B**) to unclip it completely;

- move to the left (movement **C**) to release the right-hand side of the run channel and facilitate its movement in relation to the strut;
- place the run channel **3** gently on a clean and dry surface.



Vehicles not fitted with storage compartment **A**

Due to the presence of mechanical components:

- it is forbidden to store objects under the bonnet;
- when working on the engine compartment, ensure that you do not leave anything (cloths, tools, etc.) Otherwise, this may lead to the mechanical components being damaged or cause a fire.

Risk of damage or fire;

- When working in the engine compartment, the mechanical components may be hot. The engine cooling fan may also start at any moment.

Risk of injury.

BREAKDOWN RECOVERY

42838

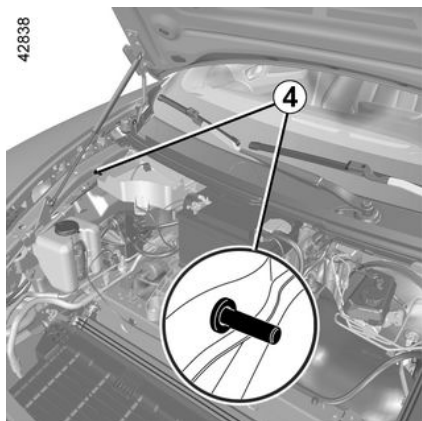

5

Refitting the scuttle panel grille run channel

It is important to properly reposition the run channel **3**.

To do this:

- position the run channel **3** (movement **D**);
- depending on the vehicle, insert the run channel **3** into the wing cover housing **6** (movement **E**);
- clip the component **5** at each end of the run channel to the bodywork mounting **4** (movement **F**);
- press the run channel (movement **G**) to clip it in.

42835

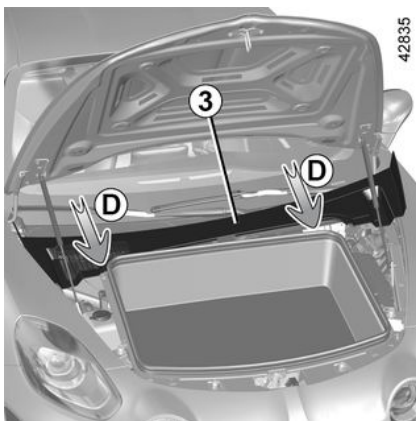

Note: if you have difficulty clipping on the run channel **3** (movement **G**), check if it has been inserted into components **4** and **6**: risk of damage to run channel.

42846

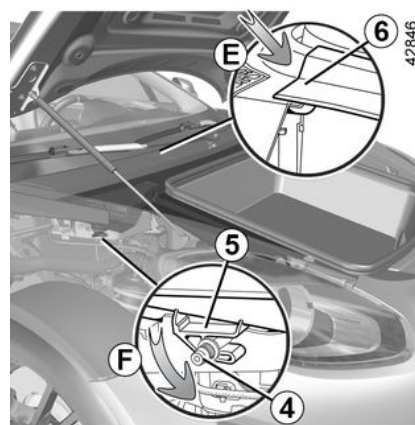

42836

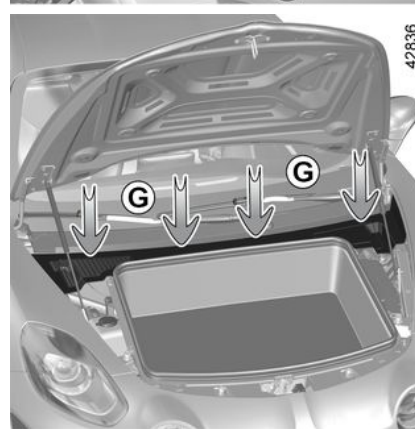

BREAKDOWN RECOVERY



Depending on the vehicle, unclip the battery cover.

Lift the red tab **11** to access the terminal **8** (+). Connect the positive cable **H** to the terminal **8** (+) then to the **terminal 9** (+) of the battery supplying the current.

Connect the negative cable **G** to the **terminal 10** (-) of the battery supplying the current and then to the **terminal 7** (-) of the discharged battery.

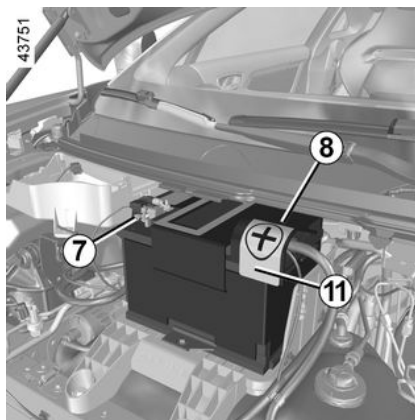

Start the engine of the vehicle supplying the current and run it at intermediate engine speed.



Ensure that there is no contact between cables **G** and **H** and that the positive cable **H** is not in contact with any metallic component in the vehicle supplying the current.

Risk of injury and/or damage to the vehicle.

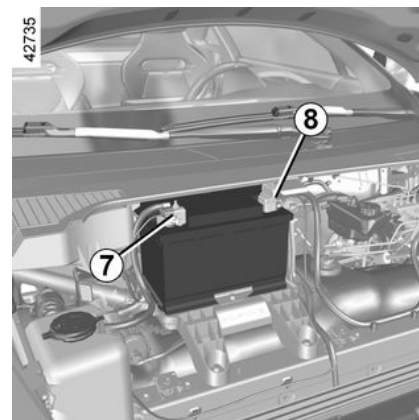

If your vehicle's engine does not start immediately, switch off the ignition and wait a few seconds before repeating the operation.

With the engine switched running, disconnect cables **G** and **H** in the reverse order (**7 - 10 - 9 - 8**).

HEADLIGHTS, LIGHTS: REPLACING BULBS

Exterior lighting: replacing bulbs

Front headlights

LED daytime running lights and side lights 1

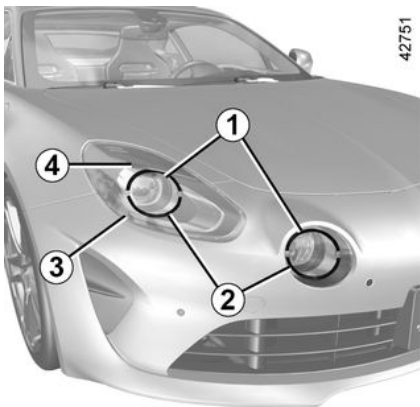

Consult an approved dealer.

LED main beam headlights 2

Consult an approved dealer.

LED dipped beam headlights 3

Consult an approved dealer.

LED direction indicator lights 4

Consult an approved dealer.



Any operation on (or modification to) the electrical system must be performed by an approved Dealer since an incorrect connection might damage the electrical equipment (harness, components and in particular the alternator). In addition, your Dealer has all the parts required for fitting these units.

Rear and indicator lights

Side lights/brake and direction indicator lights 1

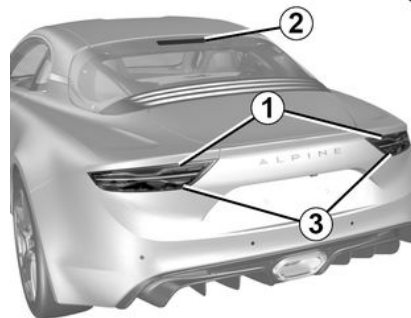

Consult an approved dealer.

High level brake light 2

Consult an approved dealer.

Reversing lights and rear fog lights 3

Consult an approved dealer.

HEADLIGHTS, LIGHTS: REPLACING BULBS

Number plate lights 4

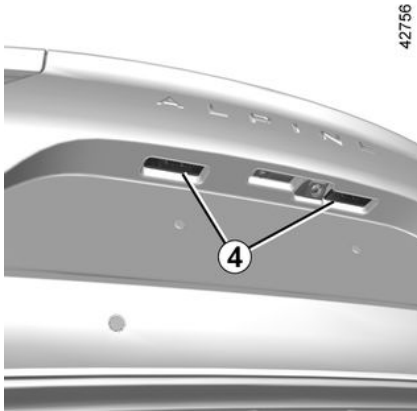

Consult an approved dealer.

Side indicator lights 5

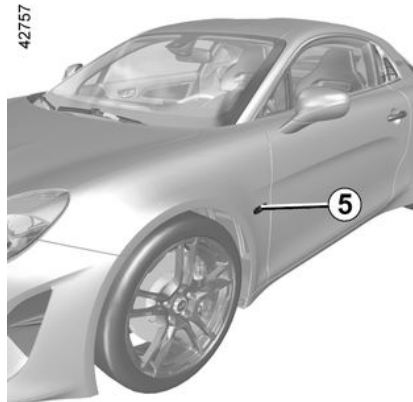

Consult an approved dealer.

Interior lighting: changing bulbs

Changing bulbs

Courtesy light 1

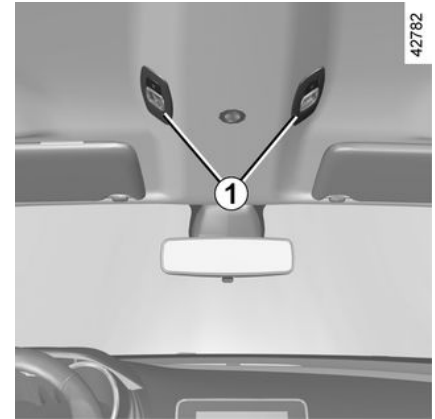

Consult an approved dealer.

HEADLIGHTS, LIGHTS: REPLACING BULBS

Bonnet storage compartment light 2

42758

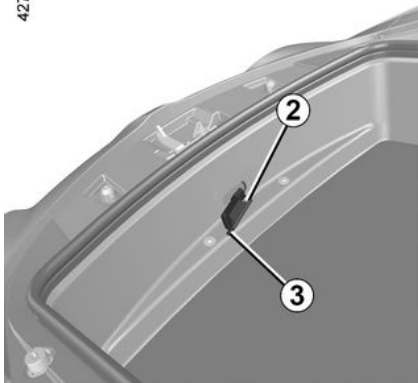

- Unclip the light **2** by pressing the tab **3**;
- remove the light cover to gain access to the bulb.

Bulb type: W5W .

42759

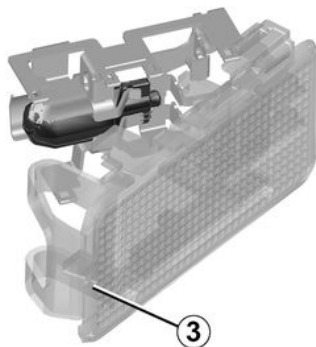

Light for luggage compartment 4

42693

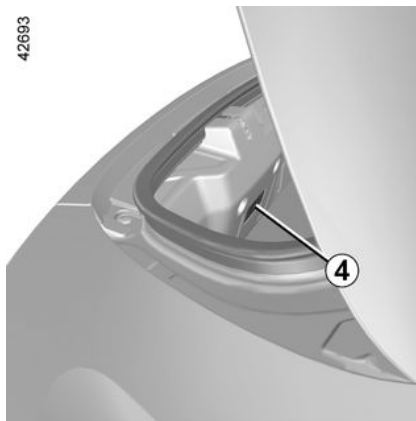

Unclip the light **4** by pressing the tab to its left (using a flat-bladed screwdriver or similar).

Remove the bulb concerned.

Bulb type: W5W .



The bulbs are under pressure and may break when replaced.

Risk of injury.

MAP

Battery

Replacing the battery

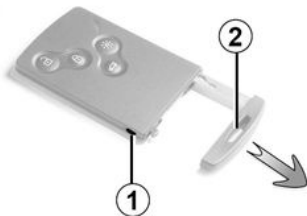

26860

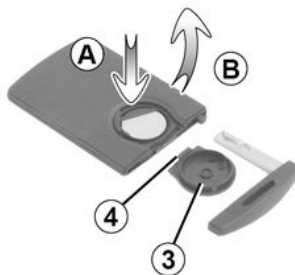

26862

When the "Keycard Battery Low" message appears on the instrument panel, replace the card battery: press button **1** while pulling the emergency key **2** then unclip the cover **3** using the tab **4**.

Remove the battery by pressing on one side (movement **A**) and by lifting the other (movement **B**) then replace it, observing the polarity and model indicated on the cover **3**.

To refit, proceed in the reverse order then press one of the buttons on the card four times while you are near the vehicle: the next time the vehicle is started, the message will disappear.

Check that the cover is clipped shut.

Note: when replacing the battery, do not touch the electronic circuit or contacts on the card.



The batteries are available from approved Dealers, and their service life approximately two years. Check that there is no dye on the battery: risk of an incorrect electrical contact.



If they need to be replaced, be sure to use the same or equivalent type of battery (consult an Approved Dealer).



When replacing:
– make sure that the batteries are correctly inserted.

There is a risk of explosion.

– if the flap does not close correctly, do not use and keep out of reach of children.

5

MAP

Operating faults

If the battery is too flat to operate, you can still start the vehicle (insert the card into the card reader) and lock/unlock the vehicle (refer to the information on "Locking and unlocking the doors" in Section 1).

26913



Do not throw away your used batteries; give them to an organisation responsible for collecting and recycling batteries.



Precautions relating to batteries:

- keep batteries (new or used) out of reach of children;
- not to swallow the batteries.

Risk of chemical burns which may lead to death.

- if ingested or inserted into any part of the body, consult a doctor as soon as possible.

WIPER BLADES: REPLACEMENT

Replacing the windscreen wiper blades 1

42766

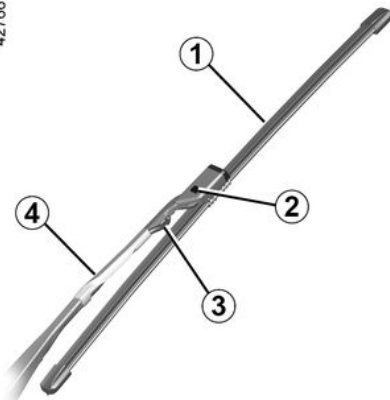

Do not raise the window wiper arm **4**.

- Lower the windscreen wiper stalk fully: the wiper blades will stop slightly away from the bonnet;
- with the ignition off, press the tab **2** on the blade **1**;
- pull the blade towards you to release it;
- disconnect the windscreen washer fluid pipe **3**.

Refitting

To refit the wiper blade, proceed in the reverse order to removal. Ensure that

the blade is locked and the screen washer fluid pipe is connected properly.

 Check the condition of the wiper blades. You are responsible for their service life:

- clean the blades and the windscreen regularly with soap and water;
- do not use them when the windscreen is dry;
- free them from the windscreen when they have not been used for a long time.



As the windscreen wiper blades **1** are **specific** to the windscreen, they must be replaced with equivalent windscreen wiper blades.
Consult an approved dealer.



– In frosty weather, make sure that the wiper blades are not stuck by ice (to avoid the risk of the motor overheating).
– Check the condition of the wiper blades.

Replace the wiper blades as soon as their performance starts to diminish (approximately once a year).

Whilst changing the blade, take care not to drop the arm onto the window after it has been removed as this may break the window.

FUSES

Allocation of fuses

(the presence and location of fuses depends on the vehicle equipment level)

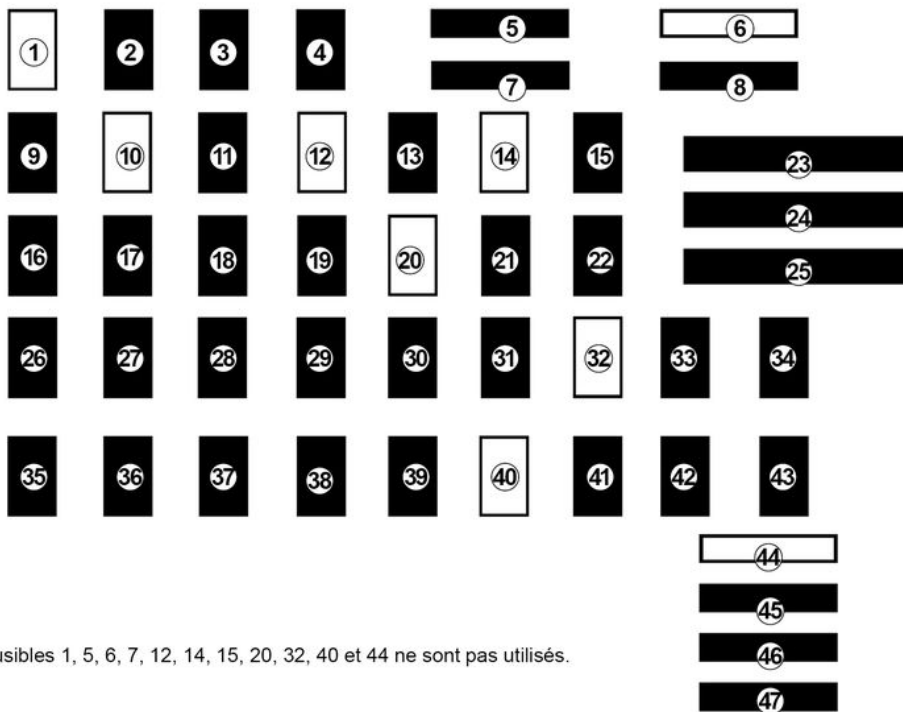

Nota : les fusibles 1, 5, 6, 7, 12, 14, 15, 20, 32, 40 et 44 ne sont pas utilisés.

42793

5

FUSES

Nomenclature

- 2** Passenger compartment ECU
- 3** Passenger side window control
- 4** Driver's electric window
- 8** Service relay
- 9** Electric heating, cruise control/speed limiter, Park Assist, heated rear screen (relay)
- 10** Heated rear screen
- 11** De-icing of electric door mirrors
- 13** Right-hand main beam headlight, left-hand dipped beam headlight, left-hand side light
- 16** Accessories socket
- 17** Light stalk
- 18** Horn
- 19** Brake lights
- 20** Radio, multimedia accessories socket
- 21** Audio amplifier
- 22** Front windscreen wiper
- 24** Left-hand main beam headlight, right-hand dipped beam headlight, right-hand side light
- 25** Rear fog lights, registration plate lights
- 26** ABS/ESC brake lights unit

- 27** Interior lighting, bonnet lighting, luggage compartment lighting, gearbox, one-touch window winder
- 28** Rain sensor, light sensor, engine start button
- 29** Electric rear view mirror
- 30** Passenger compartment unit, injection unit, fuel pump, ignition coils, starter
- 31** Airbag unit
- 33** Electric power-assisted steering
- 34** Radio, diagnostic socket
- 35** Electric windows, radio, audio amplifier, multimedia accessories socket, brake lights
- 35** interior lighting, luggage compartment lighting, bonnet lighting, air conditioning, gearbox, engine start button, rain sensor/light, ESC/ ABS unit
- 36** Energy management central unit, telematics unit
- 37** Direction indicator lights, electronic parking brake control, cruise control
- 38** Opening elements - locking / unlocking
- 39** Energy management central unit
- 41** Alarm, lighting stalk, horn
- 42** Instrument panel unit

- 43** Gearbox
- 45** Heated seats
- 46** Interior rear view mirror
- 47** Passenger compartment unit, wipe/wash stalk

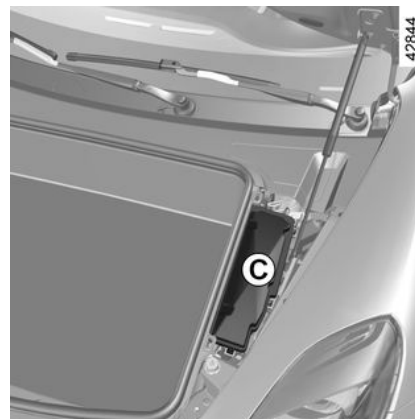

5

Some functions are protected by fuses, located:

- in the front compartment (in unit **C**);
- in the rear engine compartment (in unit **D**).

However, because of their reduced accessibility, **we advise you to have your fuses replaced by an approved Dealer.**

FUSES

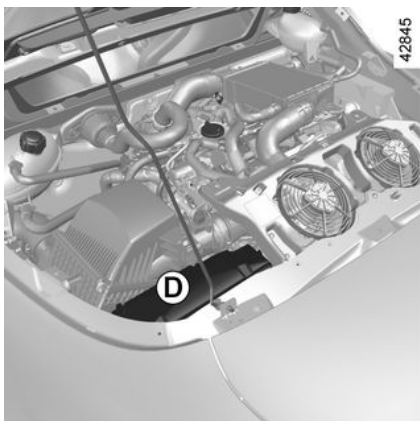

5

FITTING A RADIO

Door speakers 1

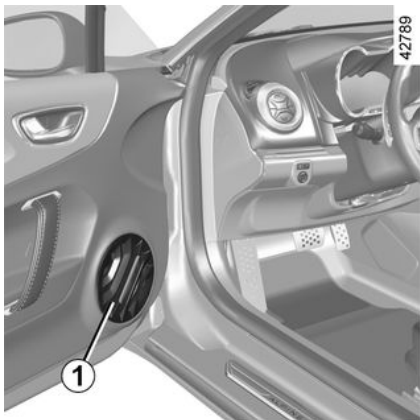

To install any equipment, please consult an approved dealer.

i – In all cases, follow the manufacturer's instructions carefully.

– The specifications of the brackets and wires (available from our network) vary depending on the equipment level of your vehicle and the type of radio.

Consult an approved Dealer to find out the correct part number.

– No work may be carried out on the vehicle's electrical or radio circuits, except by approved Dealers: an incorrectly connected system may result in damage being caused to the electrical equipment and/or the components connected to it.

INSTALLATION AND USE OF ACCESSORIES: IMPORTANT RECOMMENDATIONS



Electrical and electronic accessories

Before installing this type of accessory (particularly for transmitters/receivers: frequency bandwidth, power level, position of the aerial, etc.), make sure it is compatible with your vehicle. Contact an approved Dealer.

Before connecting an accessory to a socket, please ensure that you do not exceed the maximum power authorised for the socket (please refer to the "Multimedia equipment" and "Accessories socket" paragraphs in Section 3).

Fire hazard.

Any work on the vehicle's electrical and/or electronic circuit must only be carried out by a qualified professional. Any incorrect connection and/or installation of electrical/electronic accessories not approved by the manufacturer may cause:

- damage to the electrical and/or electronic equipment;
- damage to the components connected to it;
- the collection and use of vehicle data;
- an invasion of privacy (modification, deletion or unwarranted access to personal data).

Risk of serious accidents. Risk of invasion of privacy.

If you have electrical equipment fitted in future, make sure that you are notified of the rating and position of the corresponding fuse.

Using the diagnostic socket

The use of electronic accessories on the diagnostic socket may cause serious disturbance to the vehicle's electronic systems and/or cause invasion of privacy (modification, deletion or unwarranted access to personal data). For your safety, we recommend that you only use electronic accessories approved by the manufacturer: consult an approved dealer. **Risk of serious accidents. Risk of invasion of privacy.**

Fitting aftermarket accessories

If you wish to install accessories on the vehicle: consult an approved dealer. Also, to ensure the correct operation of your vehicle, and to avoid any risk to your safety, we recommend that you use only accessories specifically designed for your vehicle, which are the only accessories for which the manufacturer will provide a warranty.

If you are using an anti-theft device, only attach it to the brake pedal.

Driver obstruction

On the driver's side, only use mats suitable for the vehicle, attached with the pre-fitted components, and check the fitting regularly. Do not lay one mat on top of another. **There is a risk of wedging the pedals.**

OPERATING FAULTS

The following advice will enable you to carry out quick, temporary repairs. For safety reasons you should always contact an approved dealer as soon as possible.

Using the card	POSSIBLE CAUSES	ACTION REQUIRED
The card does not lock or unlock the doors.	Card battery is flat.	Replace the battery. You can still lock/unlock and start your vehicle (refer to the information on "Locking, unlocking the opening elements" in Section 1 and "Starting, stopping the engine" in Section 2).
	Use of appliances operating on the same frequency as the card (mobile phone, etc.).	Stop using the equipment or use the card's built-in key (refer to the information on "Locking, unlocking the opening elements" in Section 1).
	Vehicle located in a high electromagnetic radiation zone. Vehicle battery flat.	Use the card's built-in key (refer to the information on "Locking, unlocking the opening elements" in Section 1).
	The vehicle is started.	While the engine is on, it is not possible to lock/unlock using the card. Turn off the ignition.
	Desynchronisation of the card.	Unlock the driver's door by inserting the card's built-in key into the door lock (refer to the information on "Locking, unlocking the opening elements" in Section 1), then place the card on the placement area (refer to the information on "Starting, stopping the engine" in Section 2) and press the START button to synchronise the card.

The starter is activated	POSSIBLE CAUSES	ACTION REQUIRED
The instrument panel indicator lights are weak or fail to light up and the starter does not turn.	Battery terminals not tight, battery terminals disconnected or oxidised.	Retighten, reconnect or clean them if they are oxidised.
	Discharged battery or not operational.	Connect another battery to the faulty battery. Refer to the "Battery: breakdown recovery" information in Section 5 or replace the battery if necessary.

OPERATING FAULTS

The starter is activated	POSSIBLE CAUSES	ACTION REQUIRED
		Do not push the vehicle if the steering column is locked.
	Faulty circuit.	Consult an approved dealer.
The engine will not start.	Starting conditions are not fulfilled.	Refer to the information on "Starting, stopping the engine" in Section 2.
	The "hands-free" card does not work.	Insert the card in the card reader in order to start the engine. Refer to the information on "Starting, stopping the engine" in Section 2.
With the vehicle stationary, engine cold, the engine's idle speed is high.	This is not necessarily a fault. This may be caused by the increase in the engine temperature.	The engine's idle speed should decrease after about one minute. Otherwise, this may be caused by another fault. Consult an approved dealer.
The engine cannot be switched off.	Card not detected.	Insert the card in card reader.
	Electronic fault.	Press the starter button quickly five times.
The steering column remains locked.	Steering wheel locked.	Move the steering wheel while pressing the engine start button (refer to the information on "Starting, stopping the engine" in Section 2).
	Faulty electrical circuit.	Consult an approved dealer.

On the road	POSSIBLE CAUSES	ACTION REQUIRED
Vibrations.	Tyres not inflated to the correct pressure, incorrectly balanced or damaged.	Check the tyre pressures: if this is not the cause, have their condition checked by an approved dealer.
White smoke from the exhaust.	This is not necessarily a fault. Depending on the climate conditions (cold, humidity etc.), smoke	Reduce the engine speed and avoid sudden acceleration to gradually make the smoke disappear.

OPERATING FAULTS

On the road	POSSIBLE CAUSES	ACTION REQUIRED
	may be produced under hard vehicle acceleration.	Otherwise, this may be caused by another fault. Consult an approved dealer.
Smoke under the bonnet.	Short-circuit or cooling system leak.	Stop, switch off the ignition, stand away from the vehicle and contact an approved dealer.
The oil pressure warning light comes on:		
while cornering or braking	The level is too low.	Top up the engine oil level (refer to the information on "Engine oil level: topping up, filling" in Section 4).
is slow to go out or remains lit up under acceleration	Loss of oil pressure.	Stop the vehicle and contact an approved dealer.

On the road	POSSIBLE CAUSES	ACTION REQUIRED
Steering becomes heavy.	Assistance overheating. Fault with the electric assistance motor. Fault in the assistance system.	Drive carefully at reduced speed, be aware of the level of force in the steering wheel needed to turn the wheels. Consult an approved dealer.
The engine is overheating. The coolant temperature indicator is in the warning zone and warning light STOP comes on.	Engine cooling fan not working.	Stop the vehicle, switch off the engine and contact an approved dealer.

OPERATING FAULTS

On the road	POSSIBLE CAUSES	ACTION REQUIRED
	Coolant leaks.	Check the coolant reservoir: it should contain fluid. If there is no coolant, consult an approved dealer as soon as possible.
Coolant boiling in the coolant reservoir.	Mechanical fault: damaged cylinder head gasket.	Stop the engine. Call an approved Dealer.



Radiator: in the event of a significant lack of coolant, remember that you must never top up using cold coolant while the engine is very hot. After any procedure on the vehicle which has involved even partial draining of the cooling system, it must be refilled with a new mixture prepared in the correct proportions. Reminder: only products approved by our Technical Department may be used for this purpose.

Electrical equipment	POSSIBLE CAUSES	ACTION REQUIRED
The wipers do not work.	Wiper blades stuck.	Free the blades before using the wipers.
	Faulty electrical circuit.	Consult an approved dealer.
	Fuse damaged.	Replace the fuse or have it replaced; refer to the information on "Fuses" in Section 5.
The wiper does not stop.	Faulty electrical controls.	Consult an approved dealer.
Direction indicators flashing more quickly.	Faulty light.	Refer to the information on "Headlights: changing bulbs" or "Rear and side lights: changing bulbs" in Section 5.
The indicators are not working.	Faulty electrical circuit or control.	Consult an approved dealer.

OPERATING FAULTS

Electrical equipment	POSSIBLE CAUSES	ACTION REQUIRED
	Fuse damaged.	Replace the fuse or have it replaced; refer to the information on "Fuses" in Section 5.
The headlights or other lights do not switch on or off.	Faulty electrical circuit or control.	Consult an approved dealer.
	Fuse damaged.	Replace the fuse or have it replaced; refer to the information on "Fuses" in Section 5.

Electrical equipment	POSSIBLE CAUSES	ACTION REQUIRED
Traces of condensation in the headlights or rear lights.	Traces of condensation may be a natural phenomenon caused by variations in temperature and humidity. In this case, the traces will disappear slowly once the lights are switched on.	
The front seat belt reminder warning light comes on when the seat belts are fastened.	An object is stuck between the floor and the seat and is disrupting the operation of the sensor.	Remove all objects from underneath the front seats.

INFORMATION ABOUT THE VEHICLE

Vehicle identification plates

42791

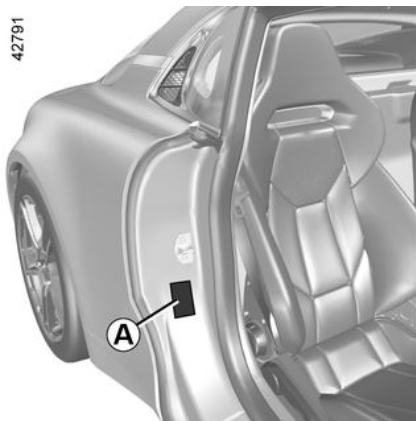

42742

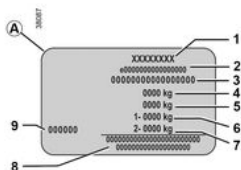
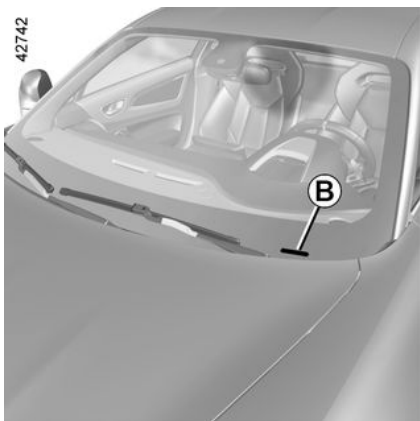

The information shown on the vehicle identification plate should be quoted on all correspondence or orders.

The presence and location of the information depends on the vehicle.

Identification plate A

1. Manufacturer name.
2. EC design number or approval number.
3. Identification number.

B. Depending on the vehicle, this information is also provided on the marking .

4. MMAC (Maximum permissible all-up weight).
5. MTR (Gross Train Weight).
6. MMTA (Maximum Permissible Weight) front axle.
7. MMTA rear axle.
8. Reserved for related or additional entries.
9. Paint reference (colour code).

INFORMATION ABOUT THE VEHICLE

Technical Information for the emergency services

61551

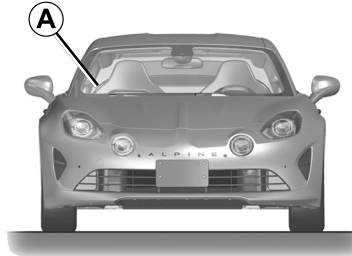

6

The QR Code on label **A** allows emergency workers to use a tablet or smartphone to immediately access technical information that is useful for working on the vehicle in the event of an accident.

Ensure that the label **A** is always visible and present on the windscreen as well as the rear screen.

Any modification or damage would prevent access to the information.

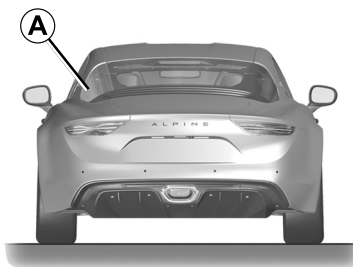

INFORMATION ABOUT THE VEHICLE

61552



INFORMATION ABOUT THE VEHICLE

Engine specifications

Versions	1.8 Tce
Engine type (see engine plate)	M5P Turbo
Cubic capacity (cc)	1798
Type of fuel Octane rating	It is essential that you use unleaded petrol of the octane rating stated on the label inside the fuel filler flap.
Spark plugs	Only use the spark plugs specified for your vehicle's engine. The type should be marked on a label affixed inside the engine compartment. If it is not then contact an approved Dealer. Fitting spark plugs which are not to specification may damage the engine.
Fuel types that meet European standards and are compatible with the engines of vehicles sold in Europe (in any other case, contact an Approved Dealer).	 Unleaded petrol compliant with standard EN 228 containing up to 5% ethanol in volume.  Unleaded petrol compliant with standard EN 228 containing up to 10% ethanol in volume.

6

INFORMATION ABOUT THE VEHICLE

Dimensions (in metres)

61553

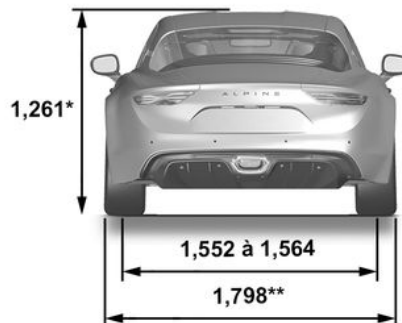
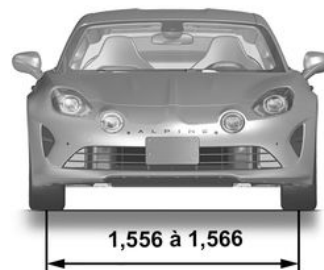
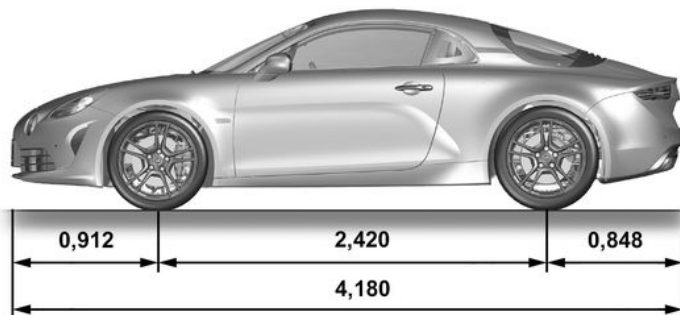

6

INFORMATION ABOUT THE VEHICLE

* unladen

** 1.854 with door mirrors folded in

INFORMATION ABOUT THE VEHICLE

Weights (in kg)

The weights indicated are for a basic vehicle without optional fittings: they vary according to your vehicle's equipment. Consult your approved Dealer.

Maximum Permissible All-up Weight (MMAC)

Maximum Permissible Weight (MMTA)

Gross Train Weight (MTR)

Weights are indicated on the manufacturer's plate (refer to the information on "Vehicle identification plates" in Section 6)

Towing Weight Braked

Prohibited

Unbraked Towing Weight

Prohibited

Permissible nose weight

Prohibited

Maximum permissible load on roof

Prohibited

6

REPLACEMENT PARTS AND REPAIRS

Original parts are based on very stringent specifications and are subjected to specific tests. Therefore, they are of at least the same level of quality as the parts fitted originally.

If you always fit genuine replacement parts to your vehicle, you will ensure that it performs well. Furthermore, repairs carried out in the approved dealer network with original parts are guaranteed according to the conditions stated on the back of the repair order.

SERVICE SHEETS

VIN:

Date:	Miles (km):	Invoice number:	Comments/miscellaneous
Type of operation:		Stamp	
Service <input type="checkbox"/>			
..... <input type="checkbox"/>			
Anticorrosion check:			
OK <input type="checkbox"/> Not OK* <input type="checkbox"/>			
Date:	Miles (km):	Invoice number:	Comments/miscellaneous
Type of operation:		Stamp	
Service <input type="checkbox"/>			
..... <input type="checkbox"/>			
Anticorrosion check:			
OK <input type="checkbox"/> Not OK* <input type="checkbox"/>			
Date:	Miles (km):	Invoice number:	Comments/miscellaneous
Type of operation:		Stamp	
Service <input type="checkbox"/>			
..... <input type="checkbox"/>			
Anticorrosion check:			
OK <input type="checkbox"/> Not OK* <input type="checkbox"/>			

6

* See specific page

SERVICE SHEETS

VIN:

Date:	Miles (km):	Invoice number:	Comments/miscellaneous
Type of operation:		Stamp	
Service <input type="checkbox"/>			
..... <input type="checkbox"/>			
Anticorrosion check:			
OK <input type="checkbox"/> Not OK* <input type="checkbox"/>			
Date:	Miles (km):	Invoice number:	Comments/miscellaneous
Type of operation:		Stamp	
Service <input type="checkbox"/>			
..... <input type="checkbox"/>			
Anticorrosion check:			
OK <input type="checkbox"/> Not OK* <input type="checkbox"/>			
Date:	Miles (km):	Invoice number:	Comments/miscellaneous
Type of operation:		Stamp	
Service <input type="checkbox"/>			
..... <input type="checkbox"/>			
Anticorrosion check:			
OK <input type="checkbox"/> Not OK* <input type="checkbox"/>			

* See specific page

SERVICE SHEETS

VIN:

Date:	Miles (km):	Invoice number:	Comments/miscellaneous
Type of operation: Service <input type="checkbox"/> <input type="checkbox"/>		Stamp	
Anticorrosion check: OK <input type="checkbox"/> Not OK* <input type="checkbox"/>			
Date:	Miles (km):	Invoice number:	Comments/miscellaneous
Type of operation: Service <input type="checkbox"/> <input type="checkbox"/>		Stamp	
Anticorrosion check: OK <input type="checkbox"/> Not OK* <input type="checkbox"/>			
Date:	Miles (km):	Invoice number:	Comments/miscellaneous
Type of operation: Service <input type="checkbox"/> <input type="checkbox"/>		Stamp	
Anticorrosion check: OK <input type="checkbox"/> Not OK* <input type="checkbox"/>			

* See specific page

SERVICE SHEETS

VIN:

Date:	Miles (km):	Invoice number:	Comments/miscellaneous
Type of operation:		Stamp	
Service <input type="checkbox"/>			
..... <input type="checkbox"/>			
Anticorrosion check:			
OK <input type="checkbox"/> Not OK* <input type="checkbox"/>			
Date:	Miles (km):	Invoice number:	Comments/miscellaneous
Type of operation:		Stamp	
Service <input type="checkbox"/>			
..... <input type="checkbox"/>			
Anticorrosion check:			
OK <input type="checkbox"/> Not OK* <input type="checkbox"/>			
Date:	Miles (km):	Invoice number:	Comments/miscellaneous
Type of operation:		Stamp	
Service <input type="checkbox"/>			
..... <input type="checkbox"/>			
Anticorrosion check:			
OK <input type="checkbox"/> Not OK* <input type="checkbox"/>			

* See specific page

SERVICE SHEETS

VIN:

Date:	Miles (km):	Invoice number:	Comments/miscellaneous
Type of operation: Service <input type="checkbox"/> <input type="checkbox"/>		Stamp	
Anticorrosion check: OK <input type="checkbox"/> Not OK* <input type="checkbox"/>			

Date:	Miles (km):	Invoice number:	Comments/miscellaneous
Type of operation: Service <input type="checkbox"/> <input type="checkbox"/>		Stamp	
Anticorrosion check: OK <input type="checkbox"/> Not OK* <input type="checkbox"/>			

Date:	Miles (km):	Invoice number:	Comments/miscellaneous
Type of operation: Service <input type="checkbox"/> <input type="checkbox"/>		Stamp	
Anticorrosion check: OK <input type="checkbox"/> Not OK* <input type="checkbox"/>			

* See specific page

SERVICE SHEETS

VIN:

Date:	Miles (km):	Invoice number:	Comments/miscellaneous
Type of operation:		Stamp	
Service <input type="checkbox"/>			
..... <input type="checkbox"/>			
Anticorrosion check:			
OK <input type="checkbox"/> Not OK* <input type="checkbox"/>			
Date:	Miles (km):	Invoice number:	Comments/miscellaneous
Type of operation:		Stamp	
Service <input type="checkbox"/>			
..... <input type="checkbox"/>			
Anticorrosion check:			
OK <input type="checkbox"/> Not OK* <input type="checkbox"/>			
Date:	Miles (km):	Invoice number:	Comments/miscellaneous
Type of operation:		Stamp	
Service <input type="checkbox"/>			
..... <input type="checkbox"/>			
Anticorrosion check:			
OK <input type="checkbox"/> Not OK* <input type="checkbox"/>			

* See specific page

ANTICORROSION CHECK

If the continuation of the warranty is subject to repair, it is indicated below.

VIN:

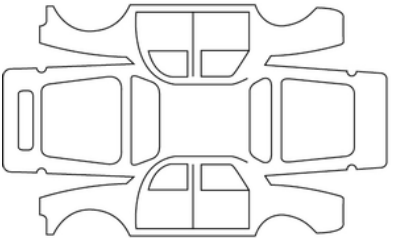
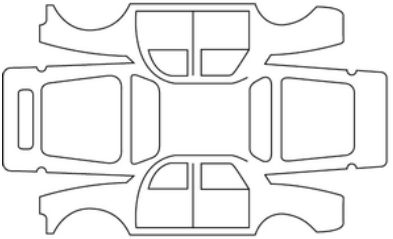
Date of repair:		Stamp
Corrosion repair operation to be carried out:		
Date of repair:		Stamp
Repair to be carried out:		

6

ANTICORROSION CHECK

If the continuation of the warranty is subject to repair, it is indicated below.

VIN:

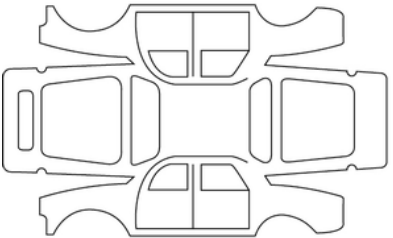
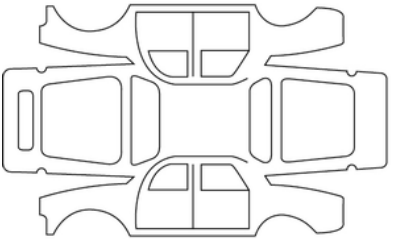
Date of repair:		Stamp
Corrosion repair operation to be carried out:		
Date of repair:		Stamp
Repair to be carried out:		

ANTICORROSION CHECK

If the continuation of the warranty is subject to repair, it is indicated below.

VIN:

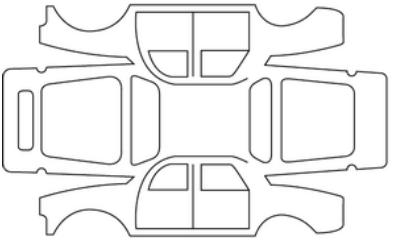
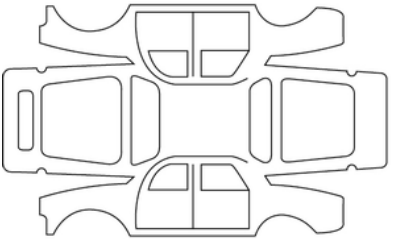
Date of repair:		Stamp
Corrosion repair operation to be carried out:		
Date of repair:		Stamp
Repair to be carried out:		

6

ANTICORROSION CHECK

If the continuation of the warranty is subject to repair, it is indicated below.

VIN:

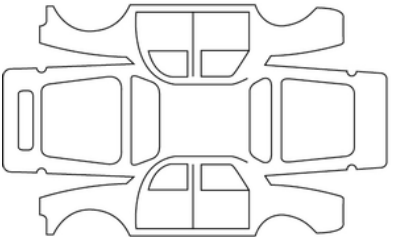
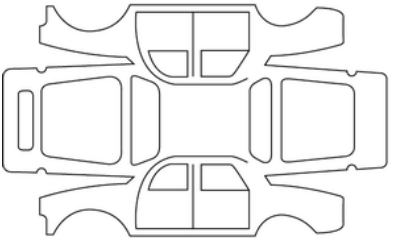
Date of repair:		Stamp
Corrosion repair operation to be carried out:		
Date of repair:		Stamp
Repair to be carried out:		

ANTICORROSION CHECK

If the continuation of the warranty is subject to repair, it is indicated below.

VIN:

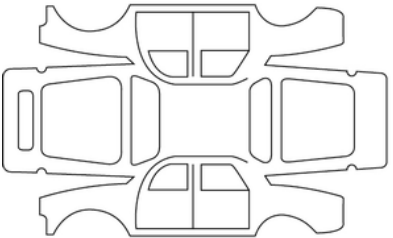
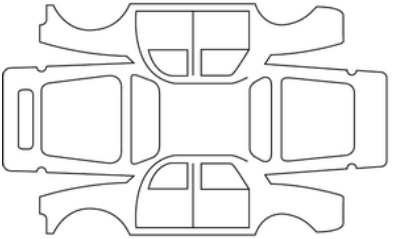
Date of repair:		Stamp
Corrosion repair operation to be carried out:		
Date of repair:		Stamp
Repair to be carried out:		

6

ANTICORROSION CHECK

If the continuation of the warranty is subject to repair, it is indicated below.

VIN:

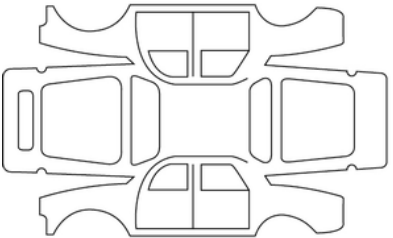
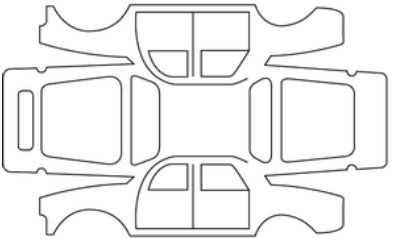
Date of repair:		Stamp
Corrosion repair operation to be carried out:		
Date of repair:		Stamp
Repair to be carried out:		

ANTICORROSION CHECK

If the continuation of the warranty is subject to repair, it is indicated below.

VIN:

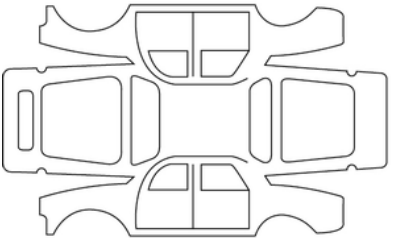
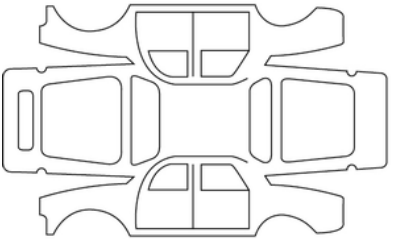
Date of repair:		Stamp
Corrosion repair operation to be carried out:		
Date of repair:		Stamp
Repair to be carried out:		

6

ALPHABETICAL INDEX

Symbols

"Hands-free" card: battery, [185](#)

"Hands-free" card: use, [4](#), [6](#)

A

ABS, [117](#)

Accessories socket, [141](#)

Access to the engine compartment, [147](#)

Adjusting the driving position, [17](#), [19](#)

Aerodynamic equipment, [161](#)

Airbag, [22](#)

Airbag : activating the front passenger airbag, [40](#)

Airbag : airbag, [22](#)

Airbag : deactivating the front passenger airbag, [40](#)

Airbags : child safety, [40](#)

Air conditioning, [133](#), [133](#), [135](#), [135](#)

Air conditioning: information and advice for use, [135](#)

Air Vents, [132](#), [133](#)

Anti-lock braking system: ABS, [117](#)

Ashtray, [141](#)

Audible and visual signals, [78](#)

Automatic gearbox (use), [96](#)

B

Battery, [178](#)

Battery: troubleshooting, [178](#)

Bodywork (maintenance), [162](#)

Bonnet, [149](#)

Brake lights, [182](#)

Bulbs: replacement, [182](#), [182](#), [182](#), [183](#)

C

Capacities: engine oil, [152](#)

Card: battery, [185](#)

Card: emergency key, [4](#)

Card: engine not starting in hands-free mode, [4](#)

Card: hands-free, [4](#)

Card: locking/unlocking the opening elements, [4](#)

Card: use, [4](#), [6](#), [11](#)

Catalytic converter, [103](#)

Central door locking, [6](#), [11](#), [14](#), [16](#)

Changing a wheel, [175](#)

Changing bulbs, [182](#), [183](#)

Changing gears, [96](#)

Children, [28](#)

Child restraint, [28](#), [36](#)

Child restraint devices, [28](#)

Child restraint system, [28](#), [36](#)

Child safety, [28](#), [36](#)

Child seats, [28](#), [33](#), [36](#)

Cigarette lighter, [141](#)

Cleaning: vehicle interior, [163](#)

Clock, [66](#), [66](#)

Closing the doors, [12](#), [14](#)

Control: emission control, [110](#)

Control instruments, [48](#), [59](#), [66](#)

Control warning lights, [48](#), [59](#)

ALPHABETICAL INDEX

Coolant level, [154](#)
Courtesy light, [140](#)
Cruise control, [123](#)
Cruise control - Speed limiter, [121](#), [123](#)
Customising the vehicle settings, [62](#)

D

De-icing/De-misting the windscreen, [133](#)
De-misting: rear window, [133](#)
De-misting: windscreen, [133](#)
Dipped beam headlights, [182](#)
Direction indicator lights, [78](#), [182](#)
Direction indicators, [78](#)
Display, [59](#)
Doors, [12](#)
Doors/Luggage compartment door, [4](#), [6](#), [11](#), [12](#), [14](#), [16](#)
Driver assistance, [117](#), [121](#), [123](#), [127](#), [128](#)
Driving, [85](#), [96](#), [103](#), [105](#), [111](#), [114](#), [117](#), [121](#), [123](#), [127](#)
Driving aids, [121](#), [123](#), [127](#), [128](#)
Driving position, [43](#)
Driving position: settings, [19](#)

E

ECO driving, [111](#)
Electric windows, [139](#)
Electronic parking brake, [105](#)
Electronic stability control: ESC, [117](#)
Emergency brake assist, [117](#)
Emergency braking, [117](#)

Emergency key, [4](#)
Emergency spare wheel, [174](#)
Emission control: advice, [110](#)
Engine: access, [147](#)
Engine oil, [151](#), [151](#), [152](#)
Engine oil dipstick, [151](#)
Engine oil level, [151](#), [152](#)
Engine start/stop button, [85](#)
Environment, [109](#)
Equipment: multimedia, [138](#), [193](#)
ESC : electronic stability control, [92](#), [117](#)
Exterior lighting and signals, [75](#)
Exterior lights, [75](#), [78](#), [182](#)

F

Fitting a child seat, [33](#)
Fitting a radio, [193](#), [193](#)
Fittings, [142](#)
Front headlights, [182](#)
Front seat adjustment, [17](#)
Front seat belt pretensioners, [22](#)
Front seats: adjustment, [17](#)
Fuel: filling, [82](#)
Fuel: grade, [82](#)
Fuel: tips for reducing consumption, [111](#)
Fuel economy, [111](#)
Fuel tank, [82](#)
Fuel tank cap, [82](#)
Fuel tank capacity, [82](#)

ALPHABETICAL INDEX

Function " Stop and Start », [88](#)

Fuses, [188](#), [190](#)

G

Gear control, [96](#)

H

Hands-free telephone controls, [138](#)

Hazard signal, [78](#)

Hazard warning lights, [78](#)

Headlights: changing bulbs, [182](#)

Heated windscreen, [133](#)

Heating and air conditioning system, [132](#), [133](#)

Heating system, [132](#), [133](#), [135](#)

Hill start assistance, [117](#)

Horn, [78](#)

I

Indicators, [78](#), [182](#)

Instrument panel, [48](#), [59](#)

Interior lighting, [140](#), [140](#), [183](#)

Interior lighting: changing bulbs, [183](#)

Interior trim: maintenance, [163](#)

K

Key/Remote control, [11](#)

L

Levels, [147](#), [155](#)

Levels: coolant, [154](#)

Levels: engine oil, [151](#)

Lifting the vehicle: changing a wheel, [175](#)

Light call, [78](#)

Lighting signals, [75](#), [78](#)

Lights: replacing bulbs, [182](#)

Locking the doors, [4](#), [6](#), [11](#), [12](#), [14](#), [16](#)

Luggage compartment, [144](#)

M

Maintenance, [110](#)

Maintenance: bodywork, [162](#)

Maintenance: filters, [155](#)

Maintenance: interior trim, [163](#), [163](#)

Maintenance: mechanical, [151](#)

Messages on the instrument panel, [48](#)

Methods of restraint in addition to the front seat belts, [22](#)

Mode Sport, [92](#)

Multimedia equipment, [138](#)

N

Navigation, [138](#)

Navigation system, [138](#)

O

Oil change, [152](#)

ALPHABETICAL INDEX

Oil filter, [152](#)
Opening elements, [12](#)
Opening the doors, [12, 14](#)
Operating faults: card batteries, [4](#)

P

Paintwork: maintenance, [162](#)
Parking brake, [105](#)
Parking distance control, [127](#)
Passenger safety: airbag front passenger, [40](#)
Phone, [138](#)
Pretensioners, [22](#)
Puncture, [174, 175](#)
Put the engine on standby, [88](#)

R

Radio, [138](#)
Rear view mirrors, [74](#)
Remote control card: battery, [185](#)
Remote control card: use, [4, 11](#)
Replacing windscreen wiper blades, [187](#)
Restraint in addition to the seatbelts, [22](#)
Reversing camera, [128](#)
Reversing radar, [127](#)

S

Seat belts, [19, 22](#)
Side lights, [182](#)
Speakers: location, [193](#)

Special features of petrol vehicles, [103](#)
Speed limiter, [121](#)
Spotlights, [140](#)
Starting the engine, [85, 88](#)
Steering wheel: adjustment, [73](#)
Stop and Start, [88](#)
Stopping the engine, [85, 85](#)
Storage compartment, [142](#)
Storage compartments, [142](#)
Switching on the vehicle ignition, [85](#)

T

Temperature regulation, [133, 135](#)
Towing: breakdown, [177](#)
Towing eyes, [177](#)
Traction control, [92, 117](#)
Transporting children, [28, 36](#)
Transporting objects in the luggage compartment, [144](#)
Trip computer, [48](#)
Troubleshooting: battery, [178](#)
Tyre inflation, [114, 169](#)
Tyre inflation kit, [172](#)
Tyre pressure, [114, 169, 169](#)
Tyre pressure monitoring system, [114](#)
Tyres, [114, 165](#)

U

Unlocking the doors, [14](#)

ALPHABETICAL INDEX

V

Vehicle customisation settings, [62](#)

Vehicle settings personalisation menu, [62](#)

Ventilation, [133](#), [135](#)

W

Warning, [78](#)

Warning lights on the instrument panel, [48](#), [59](#)

Washing, [162](#)

Wheels (safety), [165](#)

Window wipers: blades, [187](#)

Windscreen washer, [79](#)

Wiper, [79](#), [79](#)

Wiper blades, [187](#)

Wiper blades: replacement, [187](#)



SOCIÉTÉ DES AUTOMOBILES ALPINE, SA par actions simplifiée à associé unique au capital de 3 567 564 €
AVENUE DE BREAUDE, 76200 DIEPPE - SIRET 662 750 074 / SITE INTERNET : alpinecars.com

NU 1171-13 – 60 20 020 080 - 10/2023 - Edition anglaise



6020020080

KC